



ENTRUST

User's Guide

Entrust Artista® RS4 Instant Financial Issuance System

Notice

Please do not attempt to operate or repair this equipment without adequate training. Any use, operation or repair you perform that is not in accordance with the information contained in this documentation is at your own risk.

Trademark Acknowledgments

Entrust, Sigma and the hexagon design are trademarks, registered trademarks and/or service marks of the Entrust Corporation in the United States and other countries.

Datacard is a registered trademark and service mark of Entrust Corporation in the United States and other countries.

MasterCard is a registered trademark of MasterCard International Incorporated.

Visa is a registered trademark of Visa International Service Association.

All other product names are the property of their respective owners.

Proprietary Notice

The design and information contained in these materials are protected by US and international copyright laws.

All drawings and information herein are the property of Entrust Corporation. All unauthorized use and reproduction is prohibited.

Entrust Corporation

1187 Park Place
Minneapolis, MN 55379
Phone: 952-933-1223
Fax: 952-933-7971
www.entrust.com

© 2024 Entrust Corporation. All rights reserved.

Safety

The following basic safety tips are given to ensure safe installation, operation and maintenance of equipment.

- Connect equipment to a grounded power source. Do not defeat or bypass the ground lead.
- Place the equipment on a stable surface (table) and ensure floors in the work area are dry and non-slip.
- Know the location of equipment branch circuit interrupters or circuit breakers and how to turn them on and off in case of emergency.
- Know the location of fire extinguishers and how to use them. ABC type extinguishers may be used on electrical fires.
- Know local procedures for first aid and emergency assistance at the customer facility.
- Use adequate lighting at the equipment location.
- Maintain the recommended temperature and humidity range in the equipment area.

Safe Human Interface

- Use proper lifting techniques when moving or installing the equipment.
- Use standard electrostatic discharge (ESD) precautions when working on or near electrical circuits.
- Do not defeat or disconnect safety interlocks on covers.



Warning: To avoid a possible electric shock, always unplug the system before servicing.

Liability

The WARNING and CAUTION labels have been placed on the equipment for your safety. Please do not attempt to operate or repair this equipment without adequate training. Any use, operation, or repair in contravention of this document is at your own risk.

California Prop

Warning: This product contains chemicals, including lead, known to the State of California to cause cancer, and birth defects or other reproductive harm. *Wash hands after handling.*

For more information on this warning, refer to:

<https://www.entrust.com/legal-compliance/environmental-product-certifications>

Revision Log

Revision	Date	Description of Changes
A	October 2024	First release of this document.



Contents

Chapter 1: Introduction	1
About This Manual	1
Intended Audience	1
Technical Support	1
Chapter 2: About the Printer	3
About the RS4 System	3
The Front and Right Side of the Printer	4
Single-Hopper Printer	4
Multi-Hopper Printer	5
Multi-Hopper Cartridge	7
The Left Side of the Printer	8
Inside the Printer	9
Printer Configuration Label	11
Multi-Hopper Configuration Label	13
Chapter 3: Using the Printer	15
Printer Overview	15
Equipment	15
Tasks and Users	16
Secure Encryption	16
Use the Front Panel	17
Power Button	17
User Button	17
Down Arrow, Up Arrow, and Enter Key	18
LCD Panel Icons	18
Use the LCD Panel Menus	19
Retrieve the Printer's Network IP Address	21
Retrieve an IPv4 Address	21
Retrieve an IPv6 Address	23
Print a Test Card	26
Select a Color Mode	27
Load and Replace Supplies	28
Load Cards	28
Single-Hopper Printer	28
Use the Exception Slot	29
Multi-Hopper Printer	29
Use the Multi-Hopper Exception Slide	30
Replace the Ink Ribbon	31
Replace the Cleaning Sleeve	33
Replace the Retransfer Film	35

Chapter 4: Print Cards	39
Before You Begin	39
Print from Instant Financial Issuance Software	40
Chapter 5: System Maintenance	41
Maintain the Printer	41
Printer Cleaning Schedule	42
Clean the Printer	43
Use the Isopropanol Cleaning Card	44
Single-Hopper Printer	44
Multi-Hopper Printer	45
Run the Isopropanol Cleaning Card	45
Use the Adhesive Cleaning Card	47
Single-Hopper Printer	47
Multi-Hopper Printer	48
Run the Adhesive Cleaning Card	49
Prepare the Printer for Use	50
Clean the Printhead	52
Clean the Printhead Cam Rollers	55
Empty the Printer Reject Tray	56
Chapter 6: Troubleshooting	57
Locate a Problem Within the Card Production System	58
Locate a Problem with Basic Printer Functions	59
Installation Problems	60
Card Appearance	61
Tools for Troubleshooting	61
Something did not print	61
Print quality concerns	62
Magnetic Stripe Troubleshooting	65
Advanced Troubleshooting Tools	66
Printer Card Jams	67
Clear a Card Jam in the K1 Horizontal Transport	67
Single-Hopper Printer	67
Multi-Hopper Printer	68
Clear a Card Jam in the K2 Vertical Transport	68
Clear a Card Jam in the Flipper Module	69
Repair a Broken Ink Ribbon or Retransfer Film	71
Messages and Conditions	72
Messages on the Printer LCD	72
Messages from Printer Manager	73
Other Messages	73

Respond to Messages	73
Printer Messages	74
Close and lock doors	74
100: Request not supported.....	74
103: Printer problem	74
104: Critical problem.....	74
105: Magstripe data error.....	75
106: Magstripe data not found.....	75
107: Magstripe read data error.....	75
108: Magstripe read no data.....	76
111: Card not picked	76
112: Card hopper empty	76
113: Close cover to continue.....	76
114: Cover opened during job	77
116: Magstripe not available.....	77
117: Reader not available	77
120: User paused the printer	78
122: Magstripe format problem.....	78
149: Option not installed	78
150: Print while unlocked	78
151: Failed to lock	79
153: Insert same card side 2 up.....	79
166: C2 supply out or missing.....	79
167: C2 supply not identified	80
168: C2 supply not supported	80
170: Insert new card side 1 up.....	80
171: Insert same card side 1 up.....	80
172: Insert cleaning card	80
173: Improper shutdown.....	80
175: C2 supply error.....	81
176: C2 supply type error	81
222: Firmware version mismatch	82
228: C1 printhead error.....	82
229: C2 heat sensor error	82
230: C2 heater error	82
231: C2 heated roller motion error	83
232: Retransfer debow error.....	83
233: Smart card contact fail	83
234: K1 transport card jam.....	83
235: K2 transport card jam.....	84
237: C1 supply out or missing.....	84
238: C1 supply not identified	85
239: C1 supply not supported	85
241: C1 supply type error	85
242: RT1 reject tray full	86

243: Card lost	86
245: Configuration error	86
275: Multi-hopper error	86
276: Multi-hopper card jam	86
277: Multi-hopper pick error	87
278: Insert cleaning card in H2.	87
Driver-Only Message.	87
518: Unable to print.	87

Chapter 1: Introduction



About This Manual

This manual provides user information for the Entrust Artista RS4 Instant Financial Issuance Systems. The manual includes:

- An overview of printer components and options, and a description of the system label.
- How to use the printer, including how to power the printer on and off, how to use the front panel and LCD menus, how to print a test card, how to load and replace supplies, and the basics of card processing.
- How to perform routine maintenance and troubleshooting tasks.

An additional *Installation and Administrator's Guide* is available for use by administrators or other professionals responsible for setting up the printer.

Intended Audience

The manual is intended for the printer operator who is responsible for printing cards, loading and replacing supplies, maintaining the printer, and troubleshooting error conditions.

Technical Support

Use the following to contact Entrust Technical Support.

US Phone Number	1-800-328-3996
North America	Email: north.america.cust.serv@entrust.com
Latin America and Caribbean	Email: americas@entrust.com
Europe, Middle East, and Africa	Email: emea.customer.service@entrust.com
Asia Pacific	Email: dcap.admin@entrust.com



Chapter 2: About the Printer

2

This chapter describes how to identify and access the components of the RS4 Instant Financial Issuance System.

About the RS4 System

The RS4 instant financial issuance systems use retransfer technology to produce high-quality, over-the-edge printing on a variety of PVC and non-PVC card materials. The retransfer process provides a reliable print quality on card surfaces that have minor variations, such as those due to smart chips or RFID antennas embedded in the card.

The retransfer printing process uses two types of supply: a color pigment ink ribbon and a retransfer film. Heat from a thermal printhead causes the ink pigment to release from the ribbon and adhere to the retransfer material. The film is then bonded to the card using a heat and pressure process that also applies the film to the edges of the card. The printer also has the ability to apply two layers of the retransfer film on the front side or on both sides of a card, for added durability.

The printer supports several types of color ink ribbon. The ribbon typically contains the following panels: cyan, magenta, yellow, and black (CMYK). Ink ribbons also may include an interceptor panel that prevents any ink or retransfer material from being applied to areas of the card that have a magnetic stripe or signature panel.

Refer to the printer's *Installation and Administrator's Guide* for information about how to use the ink ribbons in your card design, and a list of the ribbons available for the printer.

The printer prints at a resolution of 600 x 600 dpi. It can print on one side or both sides of the card. It also can encode data on a magnetic stripe or a smart card chip. Magnetic stripe and single-wire smart card capabilities are standard.

A 125-card input and 25-card output hopper are standard. An optional multi-hopper with six input hoppers, each with a 125-card capacity, also is available. In addition, an optional upgrade kit allows you to install a Wi-Fi module in the printer.

The ES1 embosser can be added to the RS4 system that creates the raised lettering and numbering found on financial cards (refer to the ES1 User's Manual for complete information).

Refer to "[Printer Configuration Label](#)" on [page 11](#) for more information about identifying the factory-installed options in the printer.

The Front and Right Side of the Printer

Use the following sections to become familiar with the printer.

Single-Hopper Printer

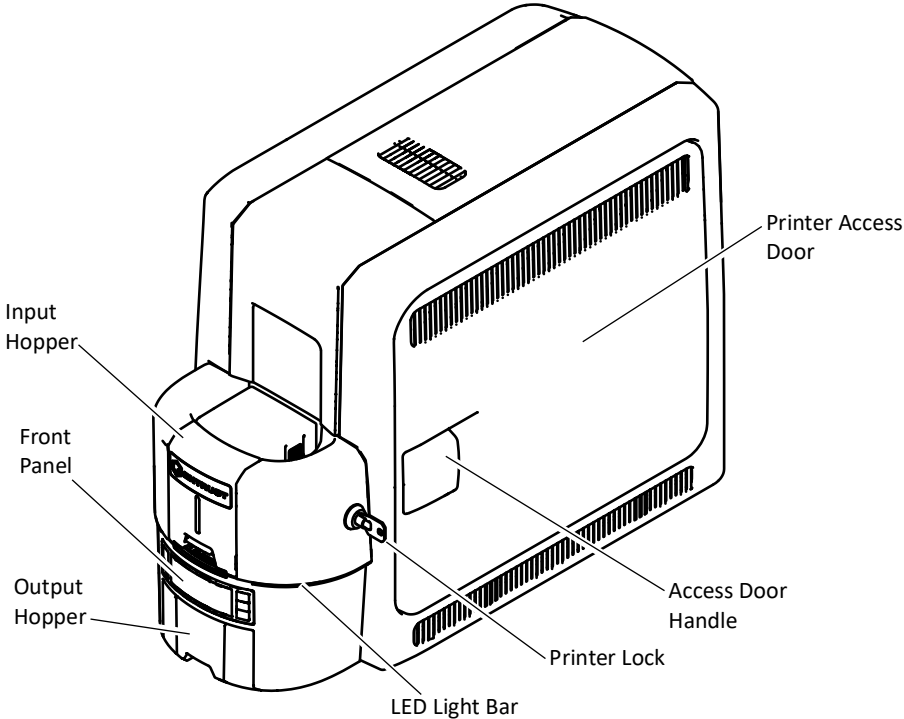

Input Hopper

The input hopper holds cards for printing. The hopper holds up to 125 cards (0.030 in. or 0.762 mm thickness).
Note: the input hopper can be removed from the printer for secure storage.

Output Hopper

The output hopper holds up to 25 completed cards.

Printer Lock

The lock secures the printer input hopper and access door. Unlock to access the inside of the printer. The lock can be opened using the key or through a command issued by an application.

Front Panel

The front panel allows you to work with the printer. It includes the POWER button, the USER button, status lights, and the LCD panel with navigation keys. Refer to [“Use the Front Panel”](#) on [page 17](#) for a description of the front panel items.

LED Light Bar

The LED light bar blinks to indicate a printer error status. It is a solid color when the printer is in **Ready** status.

Printer Access Door

The access door provides access to the printer supplies and to the rear access door release. Open the door to replace supplies or clear a card jam. A slot inside the door holds the printer *User Reference Guide*, which contains instructions for performing routine printer tasks.

Access Door Handle

The handle allows you to open the printer access door.

Multi-Hopper Printer

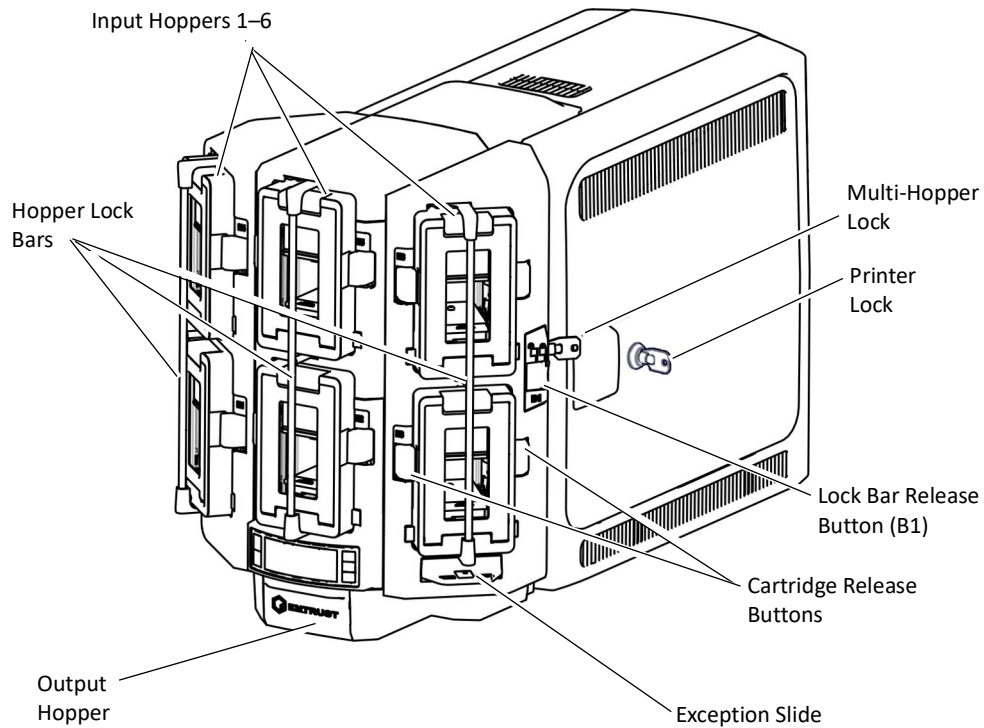

Input Hoppers 1 – 6

Each hopper cartridge in the multi-hopper holds up to 125 cards (0.030 in. or 0.762 mm thickness).

Output Hopper

The output hopper holds up to 25 completed cards.

Multi-Hopper Lock

The multi-hopper lock secures all six input hoppers. The lock can be opened using a key or a command from your card personalization software.

Sending a command to open the lock opens all locks on the printer and on any attached component.

Printer Lock

The printer lock secures the access door. Unlock to access the inside of the printer. The lock can be opened using the key or through a command issued by an application.

Lock Bar Release Button (B1)

The release button (B1) releases the lock bars in front of the input hopper cartridges. Slide the button to the left to release the bars. You must have unlocked the multi-hopper using the key or a software command before the lock bars can be released.

Hopper Lock Bars

The lock bars rotate to the left to allow access to the hopper cartridge doors, so that you can load cards into the cartridges.

Cartridge Release Buttons

The cartridge release buttons allow you to remove the cartridge from the multi-hopper unit. Push in the buttons, squeeze the cartridge, and pull it out from the multi-hopper.

Notes:

- You do not need to remove a hopper cartridge to load cards.
- Hopper cartridges can be removed for secure storage.

Exception Slide

The exception slide allows you to insert a single card into the printer without unlocking the multi-hopper or opening a hopper cartridge. Refer to [“Use the Multi-Hopper Exception Slide”](#) on page 30.

Multi-Hopper Cartridge

The multi-hopper cartridges can be pulled out from the multi-hopper unit. You can remove the cartridges with the cards inside and store them securely, if necessary.

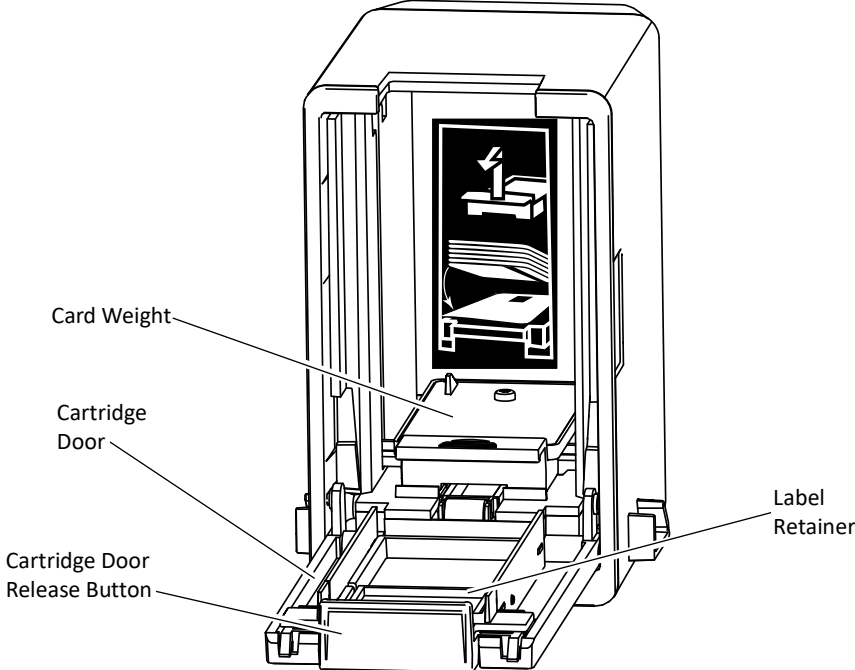

Cartridge Door Release Button

The door release button allows you to open the cartridge door. Press down on the release button.

Cartridge Door

The cartridge door swings down to provide access to the cartridge to load cards.

Card Weight

The card weight maintains a downward pressure on the loaded cards so that they enter the printer properly. Lift the card weight to the top of the cartridge and gently pull it forward until it locks in position. A diagram inside the cartridge shows how to position the card weight and load cards.

Note: Do not place the cards on top of the card weight.

Label Retainer

The label retainer allows you to insert a paper label inside the cartridge door. Use a label to identify the cartridge number or the type of cards loaded in each cartridge. Use a flathead screwdriver to open the label retainer door.

The Left Side of the Printer

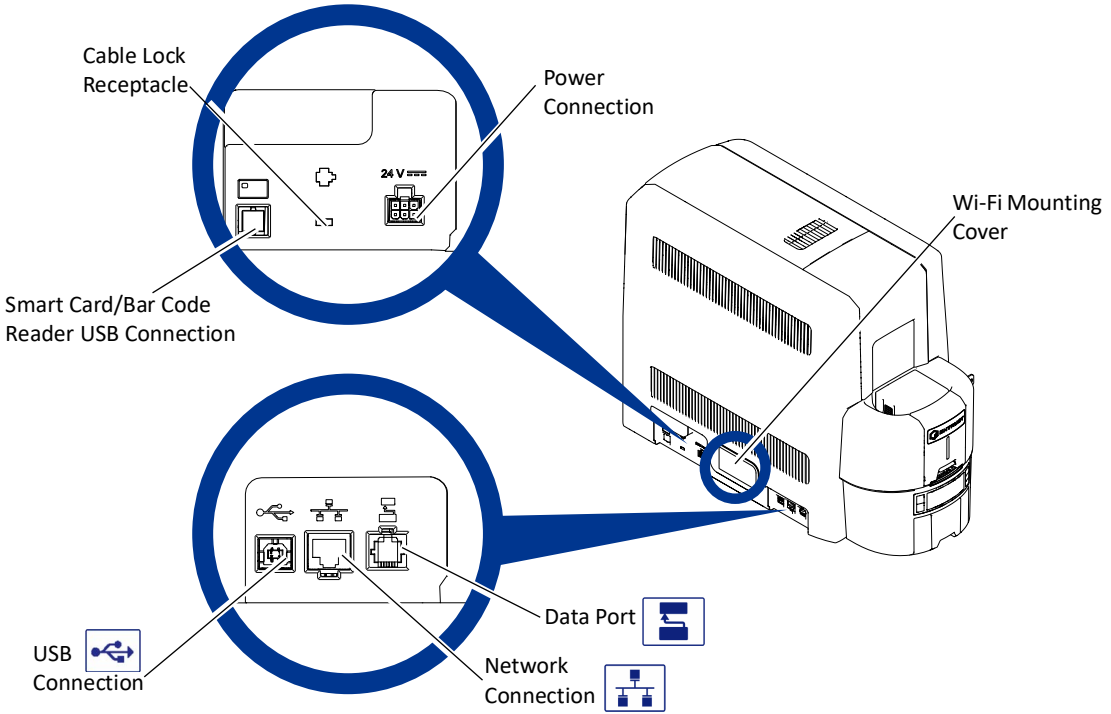

- Power Connection** The power connection provides a plug-in connector for the printer power supply.
- Cable Lock Receptacle** The receptacle allows you to insert the security plate before attaching the optional cable lock.
- Smart Card/Bar Code Reader USB Connection** The connection allows you to connect a loosely coupled smart card reader and bar code reader (used by some printers) to the computer.
- Data Port** The data port allows you to connect the printer to another component, such as the embosser.
- Network Connection** The network connection allows you to connect the printer to an Ethernet network.
- USB Connection** The USB connection allows you to connect the printer directly to a computer.
- Wi-Fi Mounting Cover** The mounting cover in Wi-Fi ready system enclosures allows you to install the optional Wi-Fi Dongle in the printer. Refer to the *Wi-Fi Upgrade Installation Instructions* for complete information.

Inside the Printer

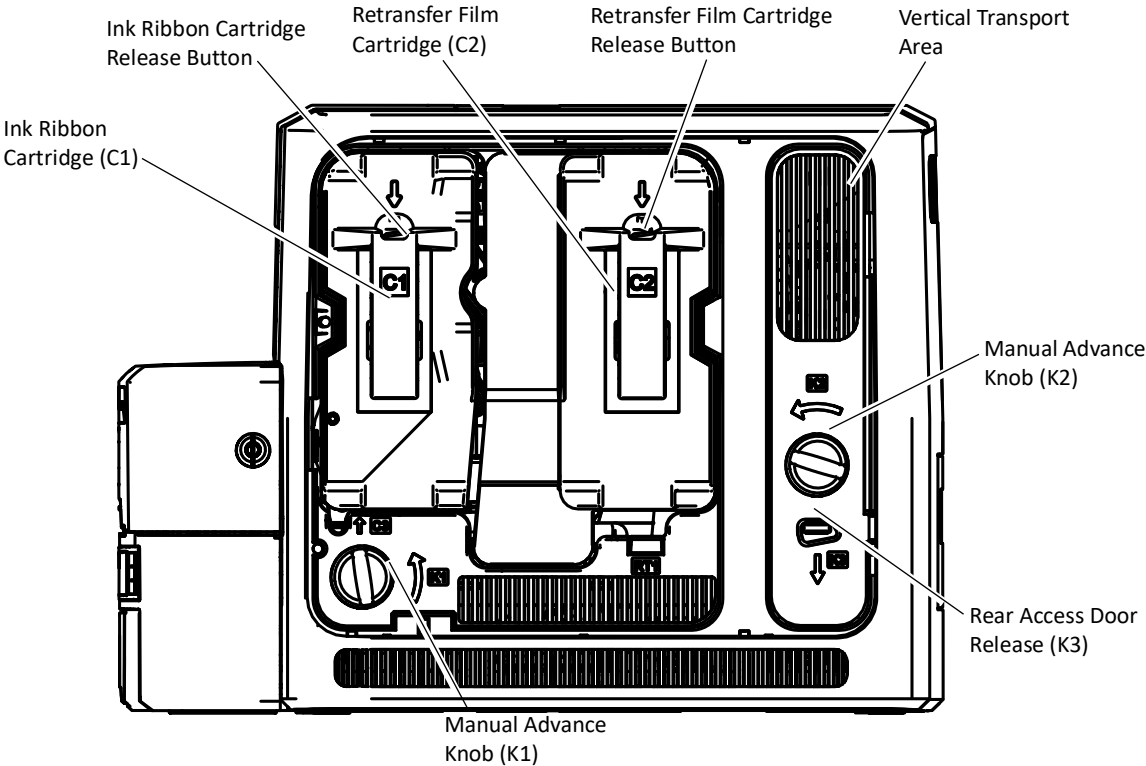

- Ink Ribbon Cartridge (C1) (blue)** The ink ribbon cartridge (C1) holds the ink print ribbon.
- Retransfer Film Cartridge (C2) (yellow)** The retransfer film cartridge (C2) holds the retransfer film.
- Cartridge Release Buttons** The ink ribbon and retransfer film cartridge release buttons allow you to remove the cartridges from the printer for loading or error recovery. Press the release button and pull the cartridge out from the printer.
- Vertical Transport** The vertical transport area houses the magnetic stripe unit and the smart card reader.

Rear Access Door Release (K3) The rear access door release (K3) opens the rear access door in the back of the printer to clear a card jam in the vertical transport.

Manual Advance Knob (K1) The manual advance knobs allow you to move a card inside the printer (K1) or in the vertical transport area (K2) to clear a card jam. The K2 knob is present only if a magnetic stripe unit or smart card reader is installed in the printer.

Manual Advance Knob (K2)

The following illustration shows the inside of the printer when the ink ribbon and retransfer cartridges are removed.

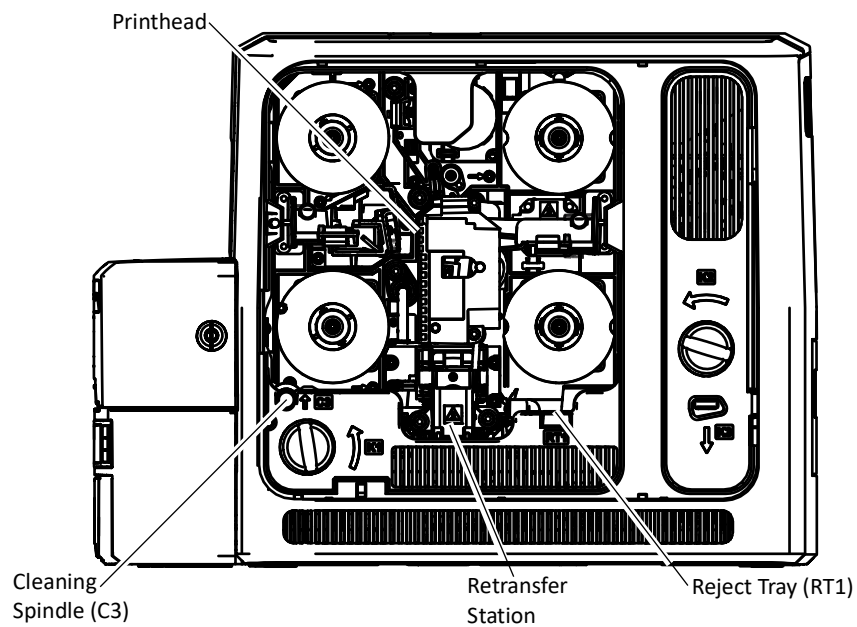

Printhead The printhead prints the card data on the retransfer film using the ink ribbon.

Cleaning Spindle (C3) The cleaning spindle (C3) holds the replaceable cleaning sleeve, which removes dust and other particles from cards to maintain print quality.

Retransfer Station

The retransfer station houses the heated roller that bonds the retransfer film containing the printed image to the surface of the card.

Reject Tray (RT1)

The reject tray (RT1) holds unfinished cards or cards that were not processed properly. Empty the reject tray regularly. Refer to “Empty the Printer Reject Tray” on page 56.

Note: If your system includes an embosser, the printer reject tray is not used. Cards are placed in the embosser reject tray. Refer to the *ES1 Embosser Module User’s Guide*.

Printer Configuration Label

The printer system configuration label shows the components installed when the printer was built. It provides information that is useful when requesting service. The label is located on the inside of the printer access door.

The label shows the following information:

- Printer model and serial number
- Configuration, which includes the factory-installed options in the printer
- Date and country of assembly
- MAC address to use when the printer is connected via an Ethernet network

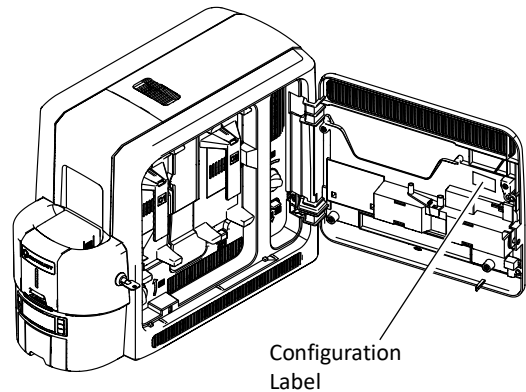

Additional labels may be attached to the printer to indicate components installed by the dealer or sales group after the printer was manufactured.

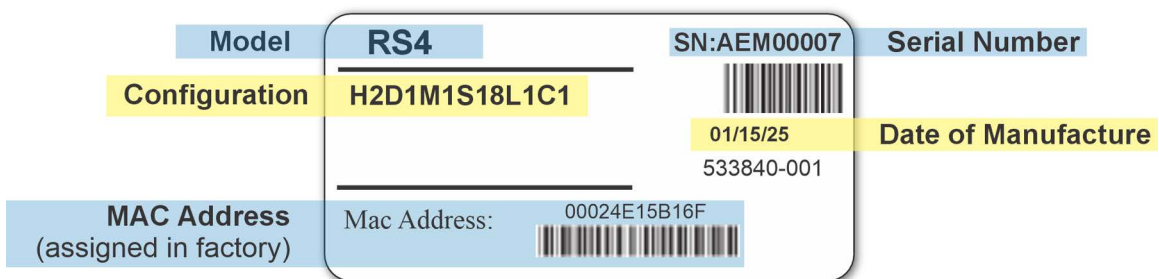

Option	Configuration Code
Input Hopper	H0=No Hopper (Multi-Hopper Ready) H2=RSx Series 125 Card Input Hopper
Duplex	D1=Duplex
Magnetic Stripe	M1=ISO M2=JIS
Smart Card	S18=Duali Single-Wire
Locks	L1=Locking Printer
Wi-Fi	W1=Wi-Fi Module blank=No Wi-Fi
Enclosures	C1=RSx Series Enclosures

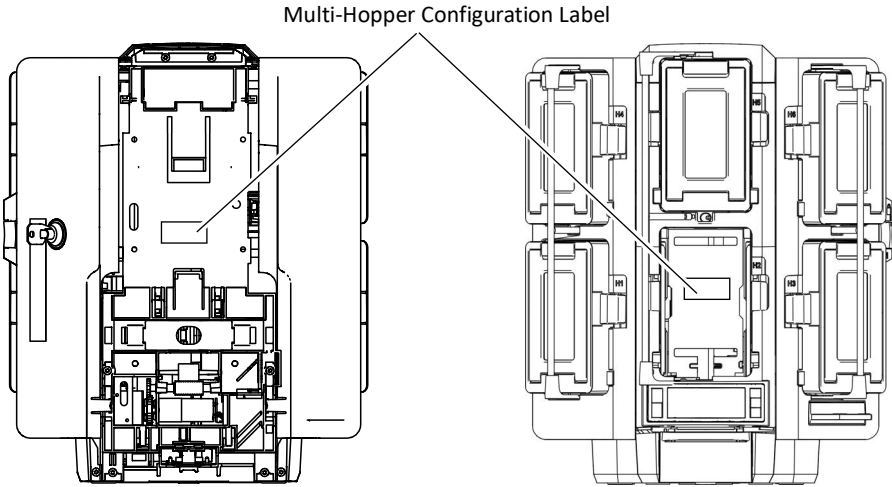

Multi-Hopper Configuration Label

The multi-hopper configuration label is located on the back of the multi-hopper. A second multi-hopper configuration label is located in the hopper receiver of the H2 cartridge. Remove the H2 cartridge to view the label.



The label shows the following information:

- The name of the multi-hopper module
- Serial number
- Part number
- Configuration code
- Date and country of assembly

Model	CMH	SN: MBM10123	Serial Number
Configuration	C1N3L1		
Date of Manufacture	06/30/24	534157-001	Part Number
	WO: 2999265		

Option	Configuration Code
Hopper Cassette Type	C1=6 125-Card Removable Input Hoppers
Printer Type	N3=RSx Series
Locks	L1=Multi-Hopper Lock blank=No lock



Caution: RSx series printers are compatible with N3 multi-hoppers only. Do not install an N1 multi-hopper on a RSx series printer. Equipment damage may result.



Chapter 3: Using the Printer

3

This chapter describes how to perform the basic tasks required to operate the printer.

Printer Overview

The RS4 Instant Financial Issuance System is used with other equipment and software to create a card personalization system. The system produces cards for a specific purpose, and the cards must meet defined requirements.

Equipment

The system can include:

- A PC with Entrust Adaptive Issuance™ Instant Financial Issuance (formerly CardWizard) software.

The RS4 system work with Instant Financial Issuance issuance software, which processes the card data and obtains the needed authorization from the financial system that manages customer accounts. Instant Financial Issuance software links to the interface used at the issuance sites.

- Capture devices (optional), such as a signature capture pad or PIN pad.
- The printer with supplies and a facility power source.
- A network data connection between the printer and PC.

Tasks and Users

Typical roles in a card personalization system include:

- The operator, who makes cards, loads supplies, and handles minor problems such as card jams.
- The system administrator, who sets up the card printer and other hardware, sets up card designs, configures card production software, and identifies the best use of the card printer in the organization

Secure Encryption

Secure encryption means that all data entered is converted into a secure form of code by your software application before it is sent to the system. The printer decrypts the code and sends the data to the magnetic stripe or smart card chip on the card.

The printer uses TLS 1.2 and 1.3 encryption for maximum security. Refer to the printer's *Installation and Administrator's Guide* for complete information about using secure printing.

Use the Front Panel

The front panel of the printer provides the controls you need to operate the system. The front panel controls are described in detail in the following sections.

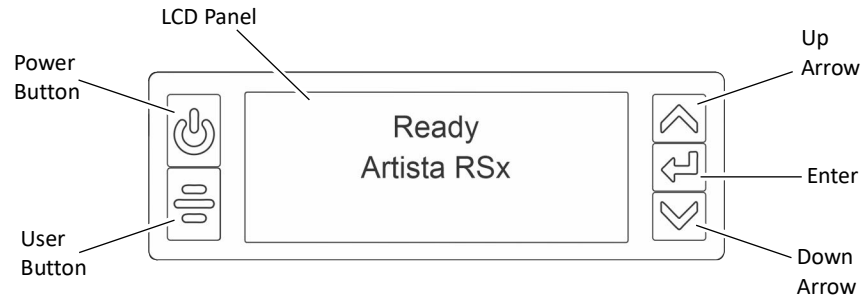

Power Button

Press the POWER button for 1 to 2 seconds to power on the printer. The printer LCD displays Initializing while the printer performs system checks and powers on.

To power off the printer, press the POWER button for 1 to 2 seconds until the printer begins to shut down.

To power off the printer while processing cards, press the button for 2 or more seconds. Card jobs in the printer do not complete.



We recommend that you do not unplug the printer power cord to power off the printer.

User Button

Press the USER button for 1 to 2 seconds to suspend the printer or to cancel a print job. Press the USER button to resume/restart a print job.

Down Arrow, Up Arrow, and Enter Key

Use the arrow keys to move through the printer menu system, and the ENTER key to make a selection.

Press the up or down arrow key while the LCD panel displays **Ready** to display additional information about the printer on line 3, including the printer serial number, IP address, supply part numbers, and firmware version. If the system includes optional components, information about those options also displays. If you do not press a key for 30 seconds, the LCD panel returns to the default **Ready** message.



- If multiple connection types are present, (for example, USB, IPv4, Wi-Fi), only the first connection address displays.
- To see the IPv6 addresses available to the printer, you must use the LCD Status menu. Refer to [“Retrieve an IPv6 Address”](#) on [page 23](#).

LCD Panel Icons

The LCD panel displays icons to indicate the status of the printer.

Icon	Description
A black icon representing a Wi-Fi signal, consisting of three curved lines radiating from a central point.	WiFi is enabled and connected.
A black icon representing a Wi-Fi module, consisting of three curved lines radiating from a central point with a diagonal slash through them.	WiFi module is installed, but not connected.
A black icon representing a cloud connection, consisting of a simple cloud shape.	Cloud connection is active.
A black icon representing a cloud connection that is not active, consisting of a simple cloud shape with a diagonal slash through it.	Cloud is enabled but not connected.
A black icon representing a card supply issue, consisting of three overlapping rectangular shapes representing cards.	There is an issue with the card supply. Additional information displays on line 3 of the LCD panel. The LED light bar blinks. Refer to xxx for a list of LCD messages that correspond to card issues. The cards icon displays on the LCD panel with the message “Cleaning Needed” when the printer has reached the preset card count to request cleaning. Run a cleaning card to reset the card count. The cards icon no longer displays on the LCD panel when the cleaning card procedure is complete. Refer to xxx.
A black icon representing an unlocked printer, consisting of a padlock with the shackle open.	The printer is unlocked. The LED light bar blinks.
A black icon representing a print ribbon issue, consisting of a circular shape with a diagonal slash through it and a small rectangular shape next to it.	There is an issue with the print ribbon. Additional information displays on line 3 of the LCD panel. The LED light bar blinks. Refer to xxx for a list of LCD messages that correspond to print ribbon issues.

Use the LCD Panel Menus

The LCD panel shows the printer’s menu system and displays messages and conditions.

For a list of error messages and recovery information, refer to [“Respond to Messages”](#) on page 73.

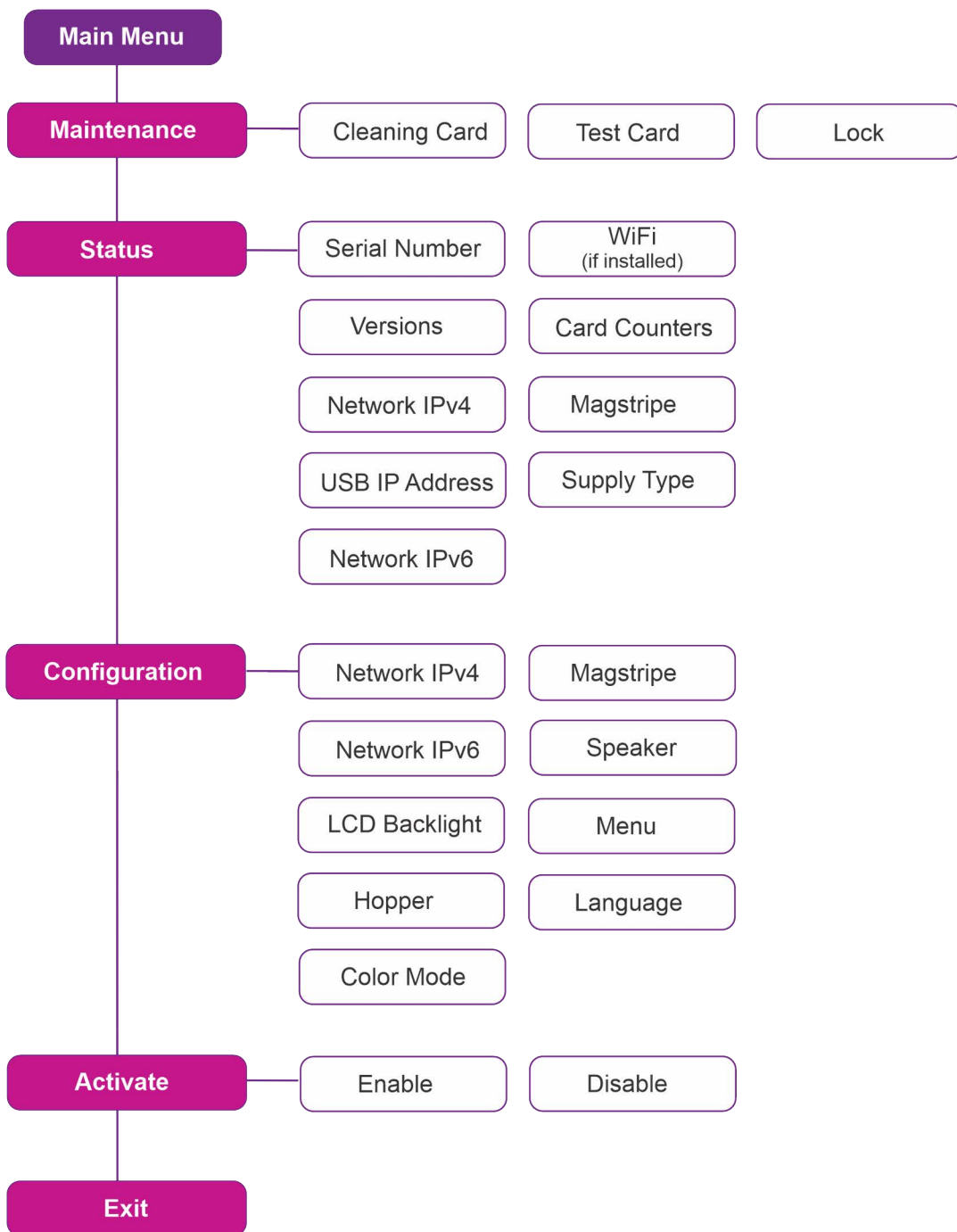

When the printer is in the **Ready** status, the LCD displays the model number of the printer.



Press the **USER** button to suspend the printer. Then, press **ENTER** to enter the menu system. Use the arrow keys to move through the menus, and press **ENTER** to make a selection. The menu system has four major branches:

- Use the **Maintenance** menu to run a cleaning card, print a test card, or reset the locks on a system with locks.
- Use the **Status** menu to see settings and data about the printer.
- Use the **Configuration** menu to change settings.
- Use the **Activate** menu to enable or disable the printer.

HINTS & TIPS

- You can access the menu system when **Ready** displays on line 1 of the LCD panel.
- The printer returns to the **Ready** status after 2 minutes of no activity. Changes that have not been applied are lost.
- To leave a selection without changing the value, press the up or down arrow key until **Exit** displays, and then press **ENTER**.

Retrieve the Printer's Network IP Address

You need the printer IP address to perform some tasks. For example, the XPS Card Printer Driver asks you to enter the network IP address during installation. You also can launch the Printer Dashboard by entering the printer IP address in a browser window.

To display the IP address, you can do one of the following:

- Press the up or down arrow key while the printer displays **Ready**. Refer to “Use the Front Panel” on [page 17](#).
- Use the LCD menu system Status menu.



If the printer is configured to use a static IP address, the printer's front panel displays the address even when the printer is not connected to a network. In addition, the LCD displays a “+” if the network is active, or a “-” if the network is inactive, as a prefix to the static IP address.

The printer supports both IPv4 and IPv6 addressing. Because an IPv6 address is much longer than an IPv4 address, the LCD displays the two types of addresses differently.

-

Retrieve an IPv4 Address

Do the following to display an IPv4 address using the Status menu. You also can display the subnet mask, gateway address, and MAC address, if necessary.

1. Begin with the printer in **Ready** status. Press the USER button.
2. **Suspended** displays on line 1 of the LCD panel. Press ENTER to enter the menu system.

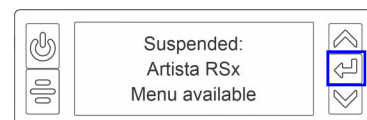

3. Access the **Status** menu in the LCD menu system:

a. Press the down arrow to display **Status** on line 3.

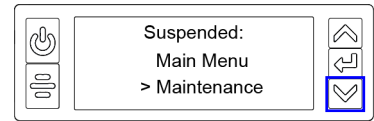

b. Press ENTER to enter the **Status** menu.

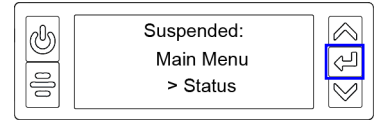

c. Press the down arrow until **Network IPv4** displays on line 3.

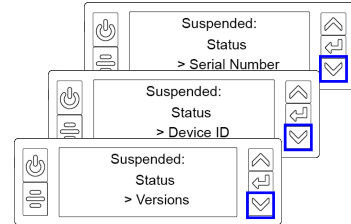

d. Press ENTER to display the **Network IPv4** menu.

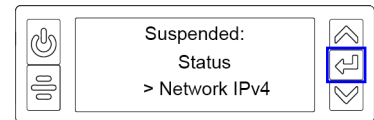

4. Press the down arrow to display **IP Address** on line 3.

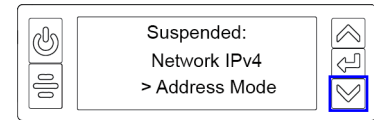

5. Press ENTER to display the IP address. Record the IP address.

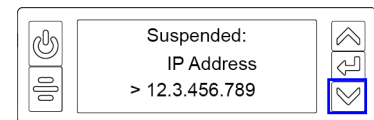
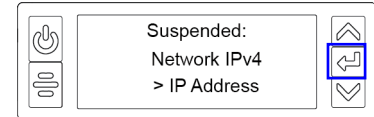

6. Press the down arrow to display the Subnet Mask on line 3. Record it, if necessary.

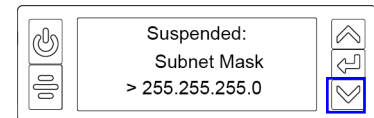

7. Press the down arrow to display the Gateway Address on line 3. Record it, if necessary.

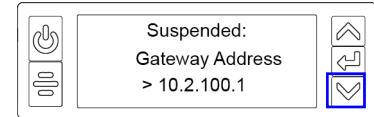

Press the down arrow again to display the MAC address of the printer.

8. Press the down arrow until **Exit** displays on line 3 and then press ENTER.

9. Press the USER button to return the printer to **Ready**.

Retrieve an IPv6 Address

A printer on an IPv6 network can be configured to use one or more of the following methods, depending on how the network is set up:

- **Link Local IPv6 address:** The printer and PC clients are restricted to the same subnet. Link local is enabled automatically when IPv6 is enabled and offers the best security for your network.
- **DHCPv6:** A DHCPv6 server is externally configured to give out an IPv6 address.
- **Stateless Address AutoConfiguration (SLAAC):** One or more routers with IPv6 enabled on the subnet give out a subnet prefix that allows access to IP addresses.
- **Manual IPv6 Address:** The printer has a designated IPv6 address on a specified subnet. The address does not change without manual intervention. This is similar to an IPv4 static IP address.

The method used can be enabled or disabled using the LCD Configuration menu or the Printer Dashboard. Refer to the Printer Dashboard Help for more information about enabling IPv6.

To display an IPv6 address using the Status menu, do the following.

1. Begin with the printer in **Ready** status. Press the USER button.
2. **Suspended** displays on line 1 of the LCD panel. Press ENTER to enter the menu system.
3. Access the **Status** menu in the LCD menu system:
 - a. Press the down arrow to display **Status** on line 3.
 - b. Press ENTER to enter the **Status** menu.

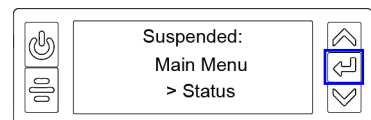
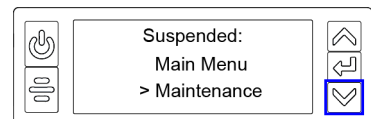
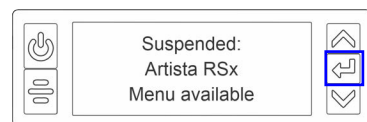

- c. Press the down arrow until **Network IPv6** displays on line 3.

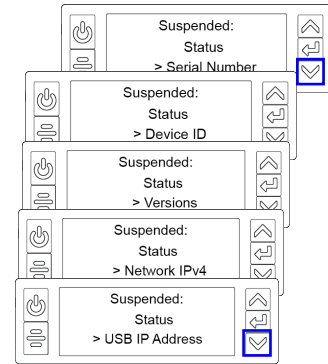

- d. Press ENTER to display the **Network IPv6** menu.

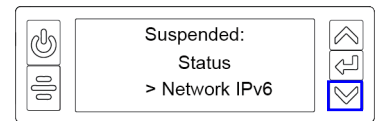

- 4. Press the down arrow until the address method used by your network displays on line 3.

- DHCP
- SLAAC
- Manual
- Local

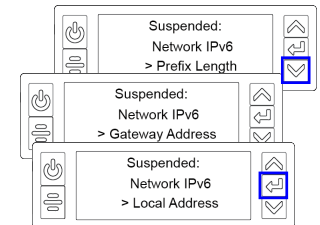
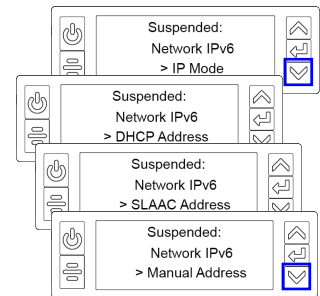

Press ENTER to display the IP address.



The following example shows the LCD display for an IPv6 Manual address. DHCP, SLAAC, and Local addresses behave the same, as does the gateway address for a manual address.

An IPv6 address is represented as eight groups of four hexadecimal digits separated by colons. The address requires 39 characters to display. Because the LCD displays a limited number of characters per line, the IPv6 address is spread across three screens of the LCD panel. You can press either the down arrow or the ENTER key to display the next section of the address. A digit at the end of line 1 indicates which section of the address is being displayed.

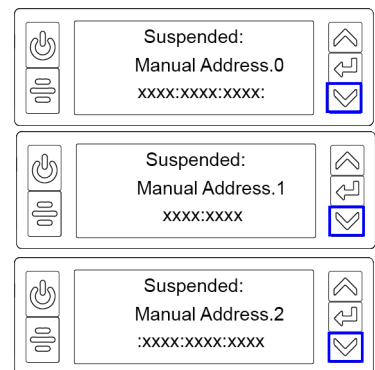



A stateless (SLAAC) configuration (if enabled) can have multiple values depending on the router setup. The LCD displays up to four SLAAC addresses. An additional digit in line 1 indicates which address is being displayed.

5. Record the address.
6. Press the down arrow until **Exit** displays on line 3.
7. Press ENTER. Then, press the USER button to return the printer to **Ready**.

Print a Test Card

The printer includes a test card that prints without using a driver or other source of card data. Use it to verify that the printer is printing correctly. Make sure that cards are in the input hopper and all supplies are loaded before you begin. Refer to “Load and Replace Supplies” on page 28 for complete information.

1. Begin with the printer in **Ready** status. Press the USER button.
2. **Suspended** displays on line 1 of the LCD panel. Press ENTER to enter the menu system.
3. **Maintenance** displays on line 3. Press ENTER to enter the **Maintenance** menu.
4. **Cleaning Card** displays on line 3. Press the down arrow to display **Test Card** on line 3.
5. Press ENTER.
6. With **Test Card** displayed on line 2, press ENTER to display **Start** on line 3.
7. Press ENTER to print the test card.

After the card prints, the printer returns to **Ready**.

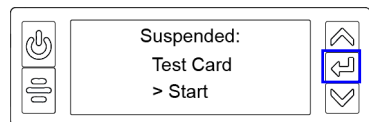
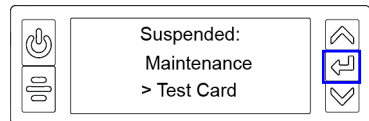
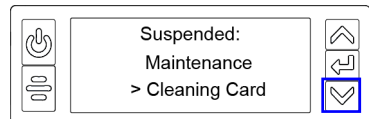
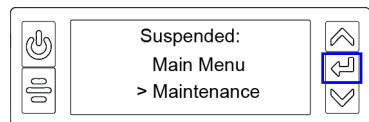

Select a Color Mode

You can use the front panel menus to select the color mode that best defines the color printing requirements for your site. The color modes are calibrated and installed in the printer during manufacturing.

You also can select the color mode using Printer Manager. Refer to the printer's *Installation and Administrator's Guide* for more information about the color modes available.

Do the following to select the color mode.

1. Press the USER button to display **Suspended** on line 1 of the LCD panel.



2. Press ENTER to enter the menu system.

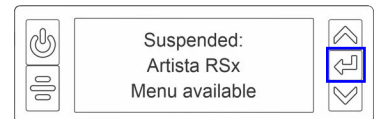

3. Press the down arrow to display **Configuration** on line 3.

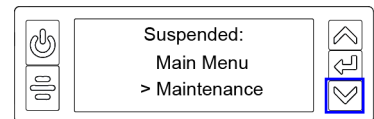

4. Press ENTER to enter the **Configuration** menu.

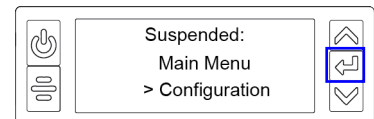

5. Press the down arrow until **Color Mode** displays on line 3, and then press ENTER to display the **Color Mode** menu.

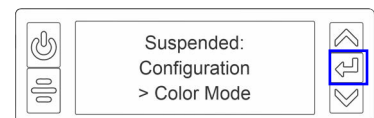

6. Press the down arrow until the color mode you want to use displays on line 3, and then press ENTER to save your selection.

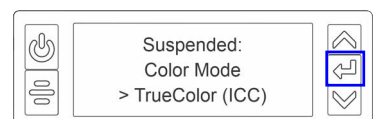

Load and Replace Supplies

To keep the printer ready to print cards, load blank card stock into the input hopper, load ink ribbon and retransfer film on the appropriate cartridges, and load a cleaning sleeve into the printer.

-  If your system includes an embosser, also load topping foil and indent ribbon into the embosser. Refer to the *ES1 Emboss Module User's Guide* for information about loading the embosser supplies.

Load Cards

Do the following to load cards in the input hopper. If you plan to insert cards manually using the exception slot, keep a supply of blank cards available.

- Handle cards by the edges only, or wear card inspection gloves approved by Entrust.
- Cards can stick together. Slide or fan the cards to separate the edges before placing them in the input hopper.
- Insert ISO magnetic stripe cards with the stripe (back side) facing down and to the right.
- Insert smart cards with the smart card chip facing up and toward the back of the hopper.

-  A diagram inside the input hopper shows the correct orientation for each type of card.

Single-Hopper Printer

1. Unlock the input hopper lock and open the input hopper door.
2. Load the cards into the input hopper. The hopper can hold up to 125 cards.
3. Close and lock the input hopper.

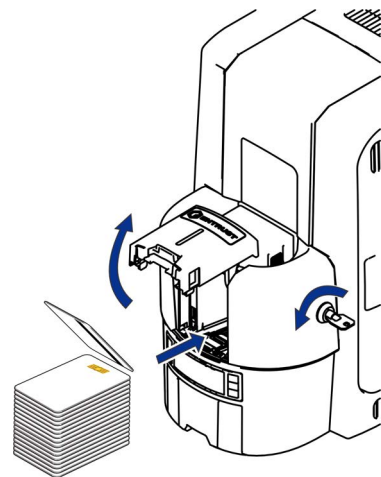

Use the Exception Slot

The exception slot allows you to insert a single card, such as a different card type than those loaded in the input hopper. The input hopper does not have to be opened to insert a card through the exception slot.

1. Slide the card into the exception slot.
2. Push the card all the way into the input hopper. The card slides under any cards already in the input hopper so that it can be picked.

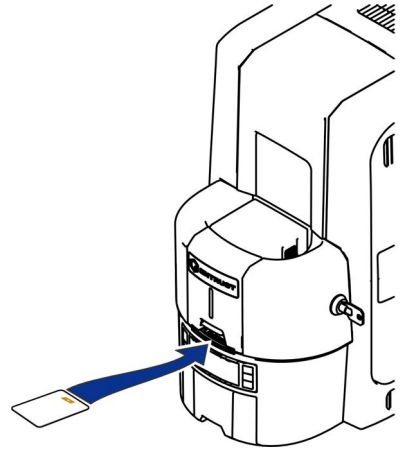

Multi-Hopper Printer

Do the following to load cards into a multi-hopper cartridge.

1. Unlock the multi-hopper lock.
2. Slide the lock bar release button (B1) to the left to release the hopper lock bars.
3. Rotate a lock bar to the left to provide access to the multi-hopper input cartridge that you want to load.
4. Press the cartridge release button at the top of the cartridge and open the cartridge door.
5. Lift the card weight to the top of the cartridge and gently pull it forward until it locks in position.
6. Load the cards into the input hopper cartridge.

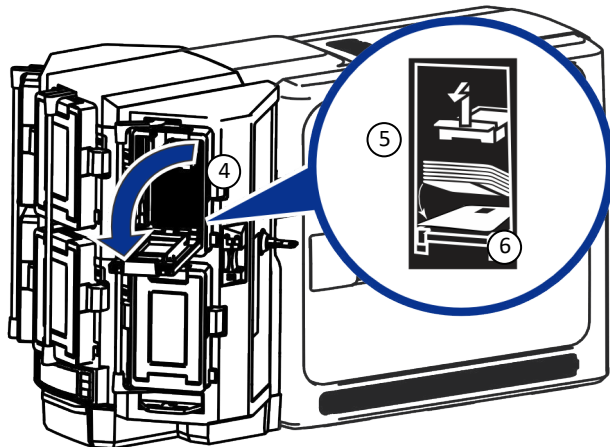
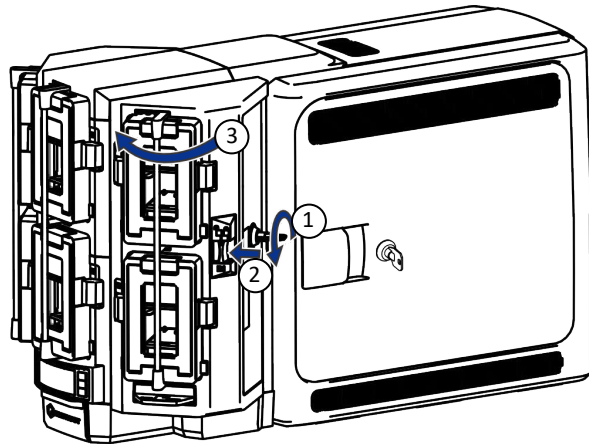



- The diagrams inside the cartridge show how to position the card weight and load cards. Do not place the cards on top of the card weight.
- You do not need to remove the cartridge from the multi-hopper.

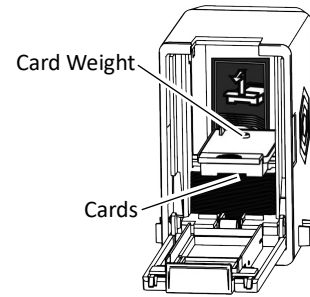

7. Close the cartridge door. This releases the card weight so that it is lowered on top of the cards.
8. Rotate the lock bar back into position.
9. Slide the lock bar release button to the right to lock the lock bars into place.
10. Lock the multi-hopper.



Caution: The lock bars, lock bar release button, and the multi-hopper door lock all must be in the lock position for the printer to operate. If any of the locks are left in the unlock position, the printer issues an error. You must unlock and re-lock all locks to clear the error and place the printer in **Ready** status.

Use the Multi-Hopper Exception Slide

Use the exception slide to insert a single card into the printer without unlocking the multi-hopper or opening a hopper cartridge.

1. Pull the exception slide out from the multi-hopper.
2. Insert the card into the exception slide tray.
3. Push the exception slide back into the multi-hopper.

The card is pulled into the printer to complete the job.

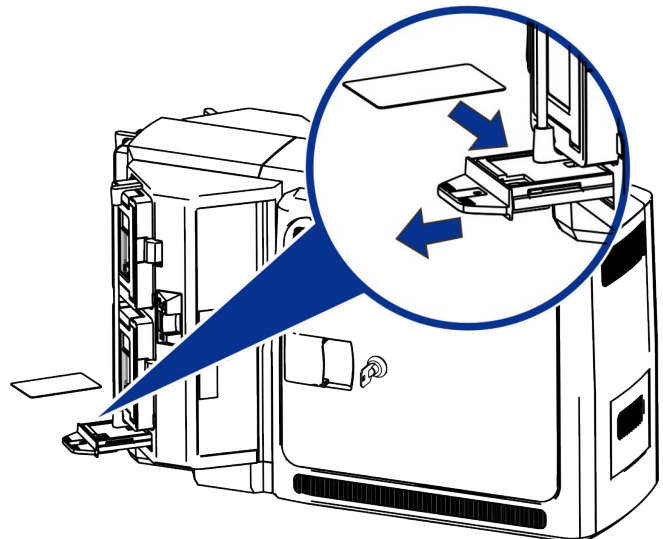

Replace the Ink Ribbon

Replace the ink ribbon when the ribbon runs out.

1. Unlock the access door lock and open the printer access door.
2. Press the ink ribbon cartridge release button and remove the blue ink ribbon cartridge (C1).
3. Place the cartridge on a flat surface with the spindles facing up.

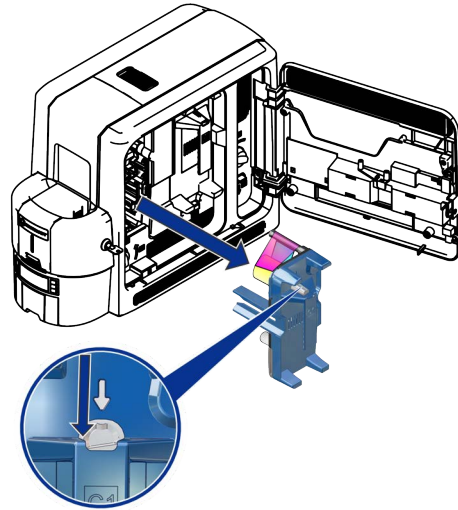

4. Remove both used spools from the cartridge.
 - a. Press the blue latch button and slide the used supply spool out from the cartridge.
 - b. Press the silver latch button and slide the full take-up spool out from the cartridge.
 - c. Follow your site's guidelines to properly discard the used ink ribbon.

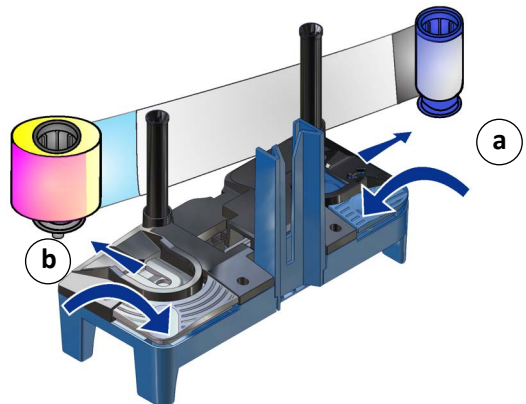

5. Clean the printer and printhead.

Each ink ribbon package contains an isopropanol cleaning card, a lapping stick, and a cleaning swab.

Refer to “Clean the Printer” on page 43 and “Clean the Printhead” on page 52 for complete information about the cleaning process.

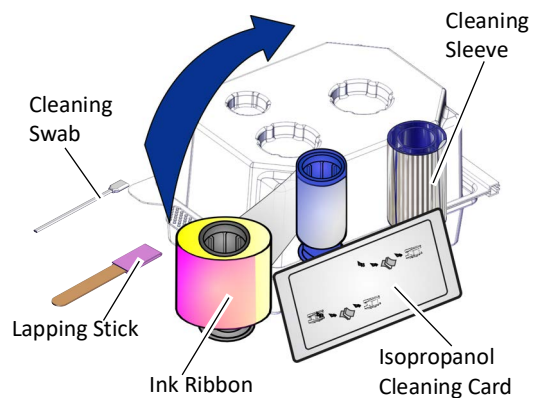

Printer best practices recommend that you clean the printer each time you install a new ink ribbon. Refer to the “Printer Cleaning Schedule” on page 42 for a complete schedule for cleaning the printer.

6. Remove the new ink ribbon from its package. Hold the ribbon cores and pull them up from the package base.



The package also includes a new cleaning sleeve. Refer to “Replace the Cleaning Sleeve” on page 33.

7. Install the ink ribbon.

- a. Slide the blue supply spool onto the cartridge until it clicks into place. The supply roll can go on only one way and fits only on the correct side of the cartridge.

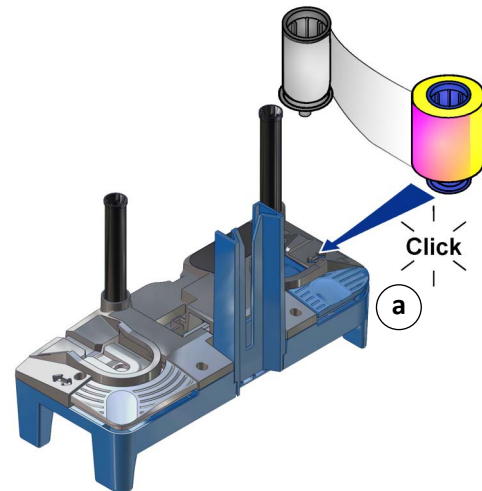

- b. Route the ink ribbon around the rollers on the cartridge. A diagram on the cartridge shows the correct routing pattern.

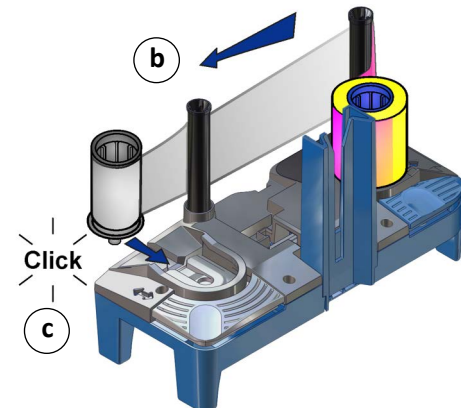

- c. Slide the empty silver take-up spool onto the cartridge until it clicks into place.

- d. Turn the take-up spool clockwise just enough to take up any slack in the ribbon.

8. Continue with “Replace the Cleaning Sleeve” on page 33.

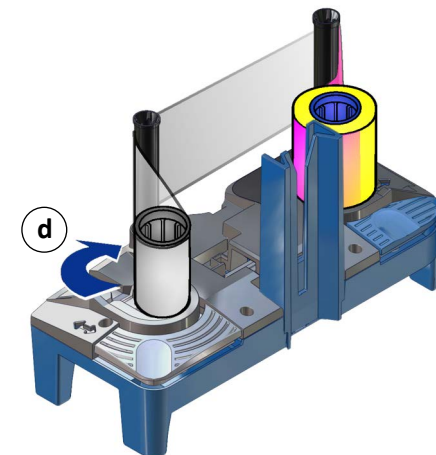

Replace the Cleaning Sleeve

The cleaning sleeve helps maintain print quality by removing dust and other particles from cards before they travel into the printer. Replace the cleaning sleeve each time you load a new ink ribbon. You also should replace the cleaning sleeve if you notice debris on the printed cards or if the cleaning sleeve is no longer sticky.

 You can access the cleaning sleeve when the ink ribbon cartridge is removed from the printer.

1. Remove the cleaning spindle from the printer.

- a. Lift up the cleaning spindle handle (C3) and pull it straight out from the printer.
- b. Remove the used cleaning sleeve from the cleaning spindle and discard it.

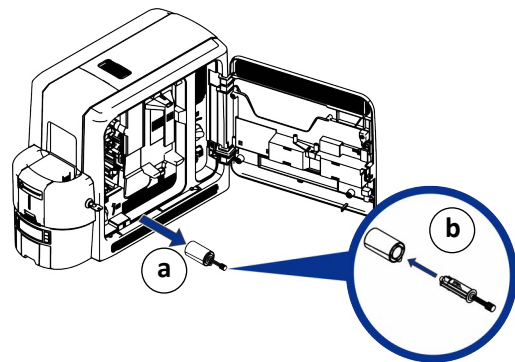

2. If you have not already done so, run a cleaning card through the printer. Refer to “Clean the Printer” on [page 43](#) for complete information about the cleaning process.

3. Load the new cleaning sleeve.

- a. Slide the new cleaning sleeve onto the cleaning spindle.

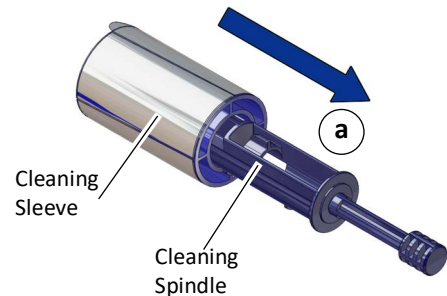

b. Remove the protective wrapper from the cleaning sleeve.

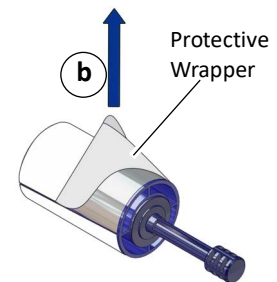

4. Replace the cleaning spindle in the C3 slot in the printer.

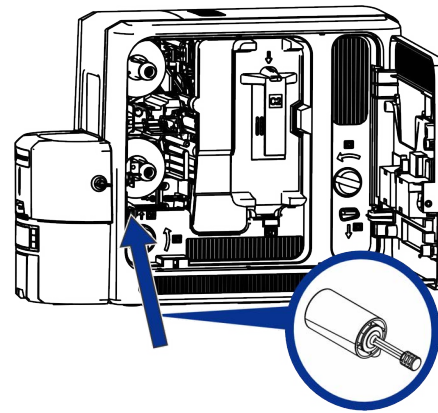

5. Replace the ink ribbon cartridge in the printer.

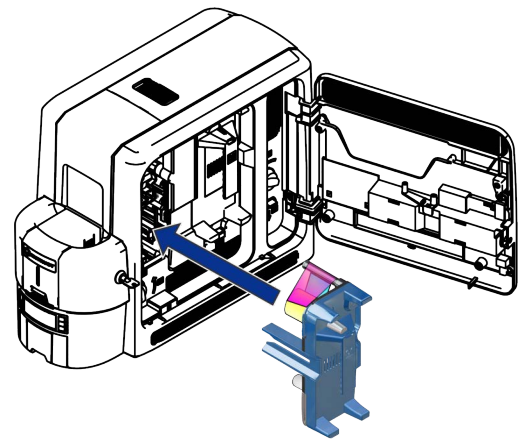

6. Close the printer access door and lock the printer.

Replace the Retransfer Film

Replace the retransfer film when the film runs out.

1. Unlock the access door lock and open the printer access door.
2. Press the retransfer film cartridge release button and remove the yellow retransfer film cartridge (C2).
3. Place the cartridge on a flat surface with the spindles facing up.

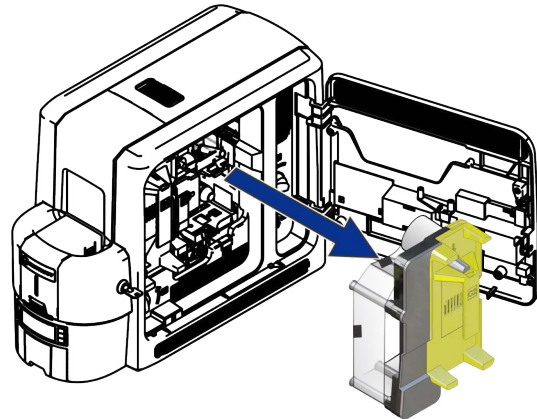

4. Remove both used spools from the cartridge.
 - a. Press the yellow latch button and slide the used supply spool out from the cartridge.
 - b. Press the silver latch button and slide the full take-up spool out from the cartridge.
 - c. Follow your site's guidelines to properly discard the used retransfer film.

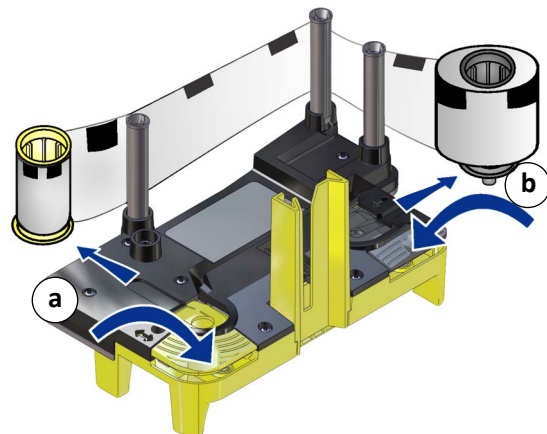

5. Remove the new roll of retransfer film from its package. Hold the film cores and pull them up from the package base.

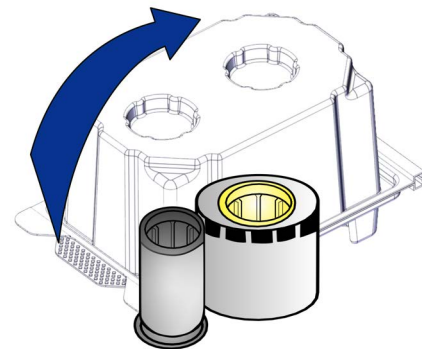

6. Install the retransfer film.

- a. Slide the yellow supply spool onto the cartridge until it clicks into place. The supply roll can go on only one way and fits only on the correct side of the cartridge.

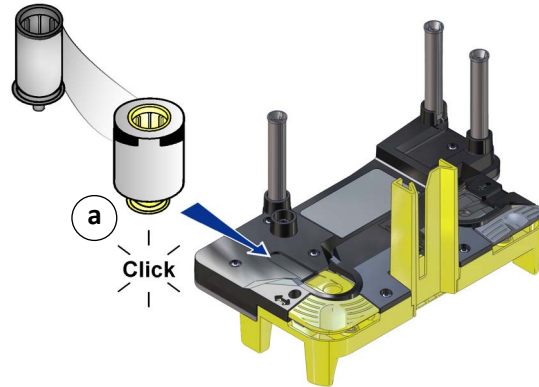

- b. Route the film around the rollers on the cartridge. A diagram on the cartridge shows the correct routing pattern.

- c. Slide the empty silver take-up spool onto the cartridge until it clicks into place.

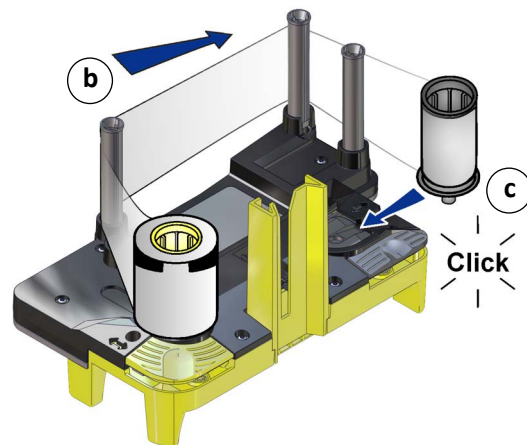

- d. Turn the take-up spool counterclockwise just enough to take up any slack in the film.

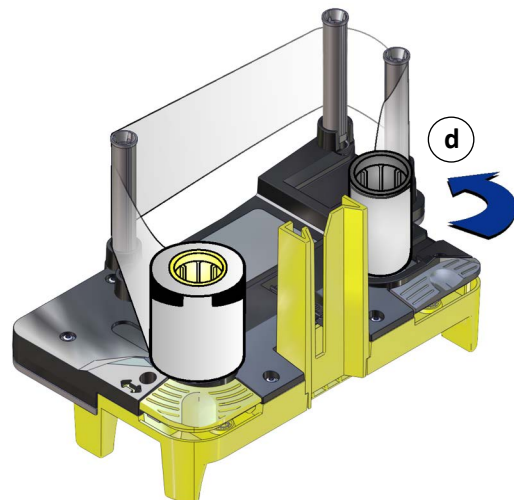

7. Remove any incomplete or rejected cards from the reject tray. Refer to [“Empty the Printer Reject Tray”](#) on [page 56](#) for more information.
8. Replace the retransfer film cartridge in the printer.
9. Close the printer access door and lock the printer.

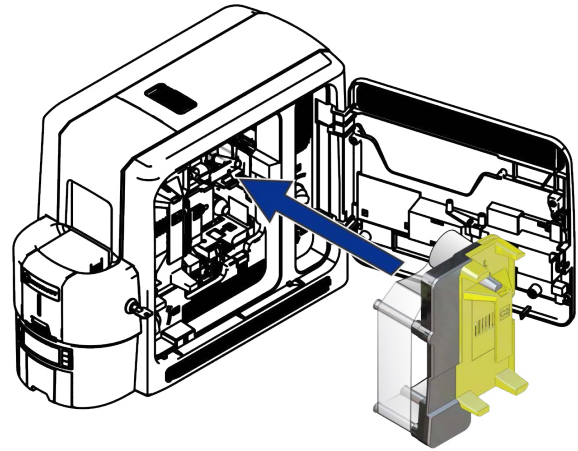



Chapter 4: Print Cards

4

This chapter provides an overview of how to use application software to prepare card designs and send card data to the printer.

Before You Begin

Before you start to print cards, make sure that you have met the following requirements:

- Cards are loaded in the printer, or available to insert.
- Ink ribbon and retransfer film are loaded. Refer to [“Replace the Ink Ribbon”](#) on [page 31](#) and [“Replace the Retransfer Film”](#) on [page 35](#). If your system includes an embosser, refer to the *ES1 Emboss Module User’s Guide* for information about preparing the embosser.
- The card design is set up. If you need to set up or modify the design, refer to [“Elements of Card Design”](#) in the printer’s *Installation and Administrator’s Guide*, and the documentation for your card personalization software.

The RS4 instant financial issuance systems use Instant Financial Issuance software to create and print cards. Instant Financial Issuance software is a centralized application that processes card data and obtains the needed authorization from the financial system that manages customer accounts.

Instant Financial Issuance software performs the following functions:

- Prepares card data
- Links to financial software, so cards issued are linked with customer accounts
- Manages security

Refer to [“Print from Instant Financial Issuance Software”](#) on [page 40](#) for instructions about how to send cards to the printer. Refer to your Instant Financial Issuance documentation for complete information about how to set up card designs and use Instant Financial Issuance software.

Print from Instant Financial Issuance Software

Instant Financial Issuance issuance software is designed to work with your financial account management system to securely issue credit and debit cards that comply with industry standards.

1. Follow the Instant Financial Issuance instructions to select a card design, and enter and save the data for the card.
2. Send the card to the printer. Instant Financial Issuance software performs verification, prepares the card data for printing, and sends it to the printer.



Chapter 5: System Maintenance

5

This chapter provides information to help you maintain your printer for optimal performance.

Maintain the Printer

The printer performs best when it is cleaned on a regular basis. Follow the cleaning guidelines for your site to keep the printer in good working condition. Refer to the [“Printer Cleaning Schedule”](#) on [page 42](#) for cleaning best practices.

You can perform the following tasks to maintain the printer:

- [Clean the Printer on page 43](#)
- [Clean the Printhead on page 52](#)
- [Clean the Printhead Cam Rollers on page 55](#)
- [Empty the Printer Reject Tray on page 56](#)

Printer Cleaning Schedule

The following schedule describes the recommended cleaning intervals for the printer. Follow this schedule to maintain the printer and obtain the best print quality.



The type of card stock you use and the printer environment can affect how often you need to perform the cleaning procedures.

Schedule	Action	Procedure
Routine Cleaning Tasks		
When you change the ink ribbon	Clean the printer with the isopropanol cleaning card.	Refer to “Use the Isopropanol Cleaning Card” on page 44.
	Replace the cleaning sleeve (C3).	Refer to “Replace the Cleaning Sleeve” on page 33.
	Clean the printhead.	“Clean the Printhead” on page 52.
Additional Cleaning Tasks		
If you see particles on completed cards	Replace the cleaning sleeve (C3).	Refer to “Replace the Cleaning Sleeve” on page 33.
	Clean the printer with the adhesive cleaning card.	Refer to “Use the Adhesive Cleaning Card” on page 47.
If you see repeating color dots on completed cards	Clean the printhead cam rollers.	Refer to “Clean the Printhead Cam Rollers” on page 55.
If you see color or white lines on completed cards	Clean the printhead	Refer to the “Clean the Printhead” on page 52

Clean the Printer

The cleaning sleeve removes dust and particles from cards before they enter the printer. However, you also need to clean the inside of the printer regularly to maintain print quality. The cleaning cards remove debris from the inside of the printer and from the transport rollers.

Two different cleaning cards are available to clean the printer:

- A double-sided, isopropanol cleaning card. An isopropanol cleaning card is included in each ink ribbon package.
- A double-sided, adhesive cleaning card that removes particles that result from the retransfer process. Use the card if you notice diminished print quality, such as a repeating pattern of spots on the card. Refer to [“Print quality concerns”](#) on [page 62](#) for additional print quality information.



The cleaning cards may become bowed slightly during shipment. If a card is bowed, insert the card into the printer as shown.

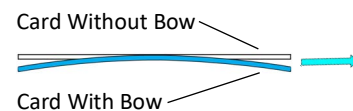

Clean the printer:

- Each time you install a new ink ribbon. Refer to [“Replace the Ink Ribbon”](#) on [page 31](#). Use the isopropanol cleaning card.
- If you notice particles on completed cards, or if print quality diminishes. Use the adhesive cleaning card.

You might need to run a cleaning card more often depending on your environment.



If the printer is located in a dusty environment and will be stored for a long period of time (for example, several months), turn off the printer and cover it with the plastic shipping bag to keep dust and other debris out of the printer.

Keep additional cleaning supplies on hand to clean the printer when needed. Refer to the printer's *Installation and Administrator's Guide* to order additional cleaning supplies.

Use the following procedures to clean the inside of the printer. Refer to the [“Printer Cleaning Schedule”](#) on [page 42](#) for cleaning best practices.

- [Use the Isopropanol Cleaning Card on page 44](#)
- [Use the Adhesive Cleaning Card on page 47](#)

Use the Isopropanol Cleaning Card

Clean the printer using the isopropanol cleaning card each time you replace the ink ribbon.



Remove the ink ribbon and retransfer film cartridges and the cleaning spindle when you clean the printer. Refer to [“Replace the Ink Ribbon”](#) on page 31, [“Replace the Retransfer Film”](#) on page 35, and [“Replace the Cleaning Sleeve”](#) on page 33 for more information.

1. Remove the isopropanol cleaning card from the ink ribbon container.
2. Open the isopropanol cleaning card package and remove the card.
Clean the printer immediately. The cleaning card dries out if it is out of its package for more than a few minutes.

3. Continue with:
 - [Single-Hopper Printer](#)
 - [Multi-Hopper Printer](#) on page 45

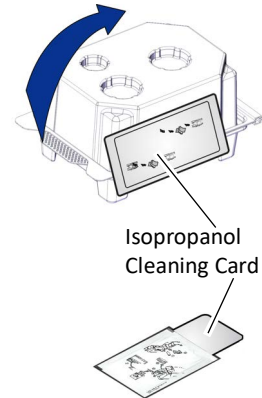

Single-Hopper Printer

1. Power on the printer, if necessary.
2. Unlock the input hopper lock.
3. Open the input hopper cover.
4. Remove any unprinted cards. Handle the cards by the edges only, or wear card inspection gloves approved by Entrust.

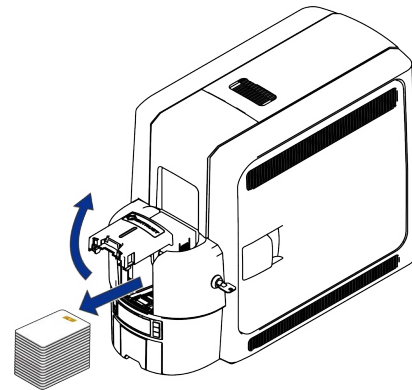

5. Load the cleaning card into the input hopper.
If the cleaning card appears bowed, insert it as shown.

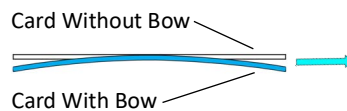

6. Close and lock the input hopper.
7. Continue with [“Run the Isopropanol Cleaning Card”](#) on page 45.

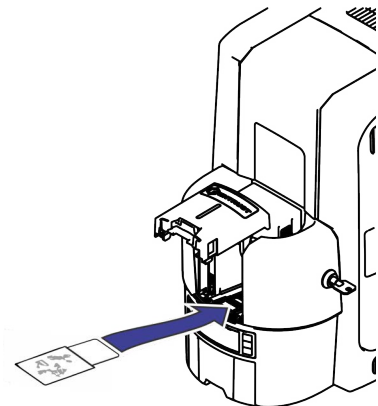

Multi-Hopper Printer

1. Power on the printer, if necessary.
2. Pull out the multi-hopper exception slide and insert the cleaning card.

If the cleaning card appears bowed, insert it as shown.

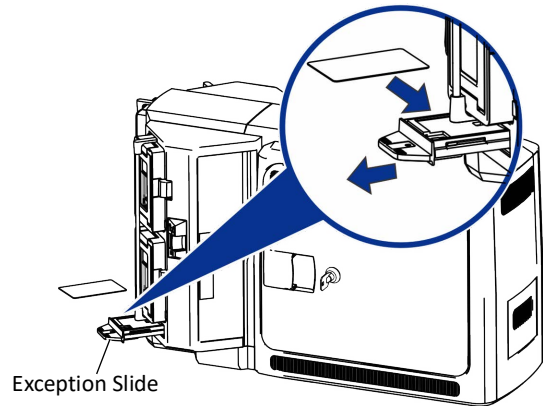
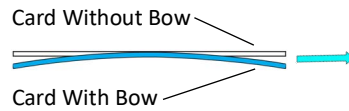

3. Push in the exception slide.
4. Continue with [“Run the Isopropanol Cleaning Card”](#).

Run the Isopropanol Cleaning Card

Use the LCD menu system to run the isopropanol cleaning card.

1. Begin when the printer displays **Ready** and the USER button shows steady green. Press the USER button.



2. **Suspended** displays on line 1 of the LCD panel. Press ENTER to enter the menu system.

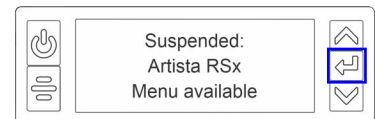

3. **Maintenance** displays on line 3 of the LCD panel. Press ENTER to enter the **Maintenance** menu.

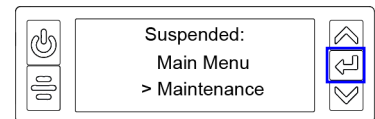

4. **Cleaning Card** displays on line 3 of the LCD panel. Press ENTER to enter the **Cleaning Card** menu.

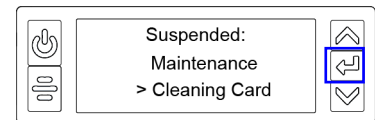

5. **Isopropanol** displays on line 3 of the LCD panel. Press ENTER to select the isopropanol cleaning card.

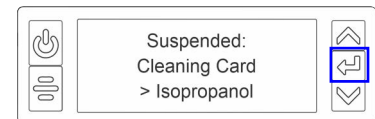

6. **Start** displays on line 3 of the LCD panel. Press ENTER to start the cleaning process.

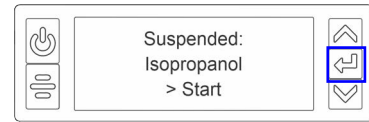

7. **Insert cleaning card** displays on the LCD panel. Press the USER button to start the cleaning cycle.

The printer moves the card through the printer several times. The card then moves into the vertical transport and cleans the rollers located there.

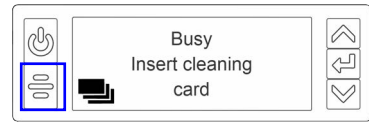

When the cleaning cycle completes, the isopropanol cleaning card is ejected into the printer reject tray (RT1). It can remain in the reject tray until the next time the tray is emptied.



When you clean a system with an ES1 Emboss Module, the isopropanol cleaning card moves into the embosser and cleans the card entry area and embosser rollers. The cleaning card is ejected into the embosser reject tray. Open the embosser to remove the cleaning card.

8. After the cleaning card is used to clean the printer, reuse it to wipe debris from the upper ribbon guide post on the ribbon cartridge.

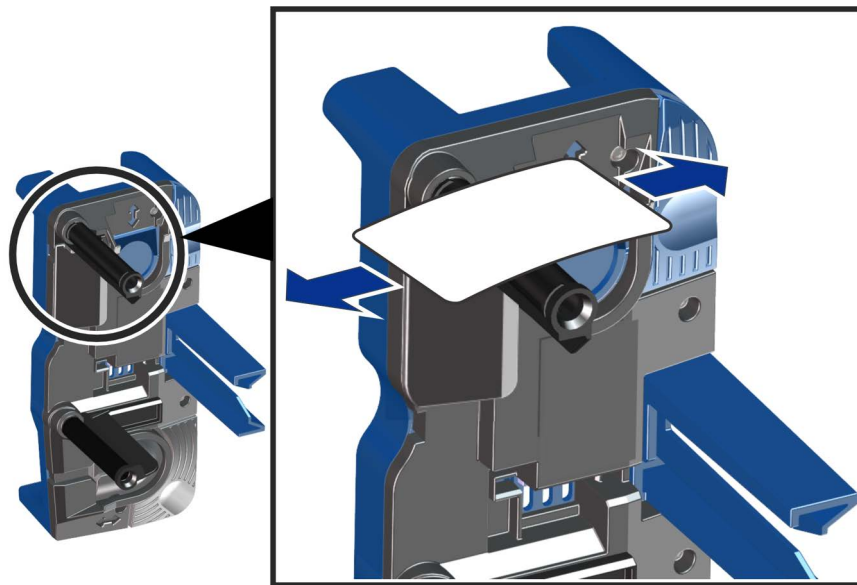

9. Continue with [“Prepare the Printer for Use”](#) on page 50.

Use the Adhesive Cleaning Card

Use the adhesive cleaning card to remove particles that result from the retransfer process. Refer to the “[Printer Cleaning Schedule](#)” on [page 42](#) for information about when to use the adhesive cleaning card.



Remove the ink ribbon and retransfer film cartridges and the cleaning spindle when you clean the printer with the adhesive cleaning card. This prevents the cleaning card from sticking to the ink ribbon or retransfer film.

Single-Hopper Printer

1. Power on the printer, if necessary.
2. Remove the supply cartridges and the cleaning spindle. Refer to “[Replace the Ink Ribbon](#)” on [page 31](#), “[Replace the Retransfer Film](#)” on [page 35](#), and “[Replace the Cleaning Sleeve](#)” on [page 33](#).
3. Unlock the input hopper lock.
4. Open the input hopper cover.
5. Remove any unprinted cards. Handle the cards by the edges only, or wear card inspection gloves approved by Entrust.
6. Peel off the center strips on both sides of the adhesive cleaning card. Leave the side strips in place.

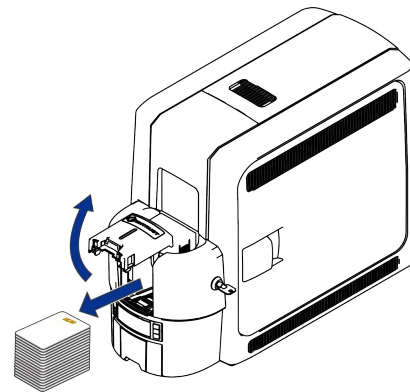

7. Load the adhesive cleaning card in the input hopper.
If the cleaning card appears bowed, insert it as shown.

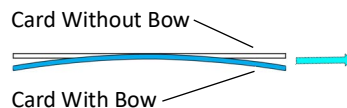

Peel Off Center Strips Only

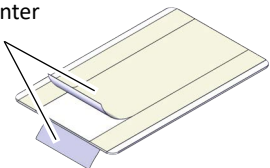

8. Close the input hopper and lock the printer.
9. Continue with “[Run the Adhesive Cleaning Card](#)” on [page 49](#).

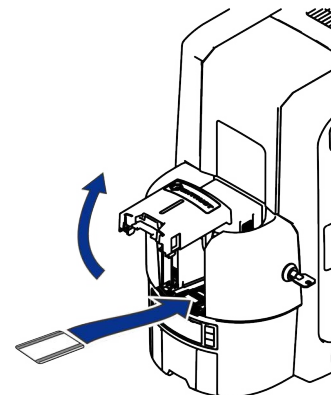

Multi-Hopper Printer

1. Power on the printer, if necessary.
2. Remove the supply cartridges and the cleaning spindle. Refer to “Replace the Ink Ribbon” on page 31, “Replace the Retransfer Film” on page 35, and “Replace the Cleaning Sleeve” on page 33.
3. Unlock the multi-hopper.
 - a. Unlock the multi-hopper door lock (a).
 - b. Slide the lock bar release button (B1) to the left to release the hopper lock bars (b).
 - c. Rotate the center lock bar to the left to provide access to the H2 and H5 multi-hopper input cartridges (c).

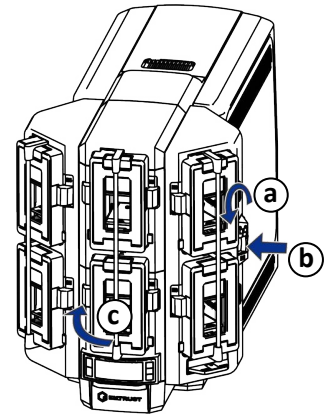

4. Press the cartridge release button at the top of the H2 cartridge and open the cartridge door (d).
5. Lift the card weight to the top of the cartridge and gently pull it forward until it locks in position (e).
6. Remove the unprinted cards from the H2 cartridge (f). Handle the cards by the edges only, or wear card inspection gloves approved by Entrust.

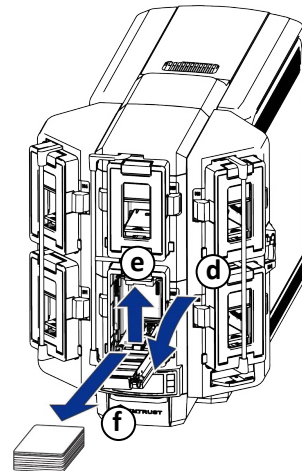

7. Peel off the center strips on both sides of the adhesive cleaning card. Leave the side strips in place.

Peel Off Center Strips Only

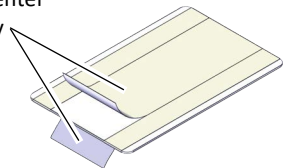

8. Load the adhesive cleaning card in the H2 cartridge and close the cartridge door (g).

If the cleaning card appears bowed, insert it as shown.

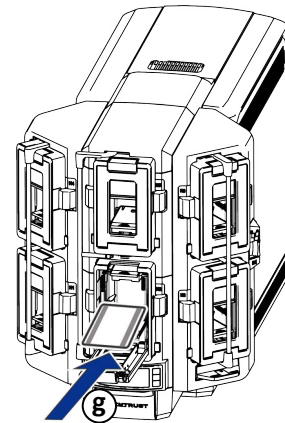
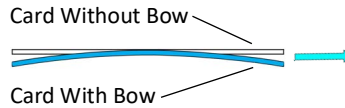

Caution: Do not insert the adhesive cleaning card in the exception slide of the multi-hopper.

9. Lock the multi-hopper.
 - a. Rotate the center lock bar to the right to the lock position.
 - b. Slide the lock bar release button to the right to lock the lock bars into place.
 - c. Lock the multi-hopper door lock.
10. Continue with “Run the Adhesive Cleaning Card”.

Run the Adhesive Cleaning Card

Use the LCD menu system to run the adhesive cleaning card.

1. Begin when the printer displays **Ready** and the USER button shows steady green. Press the USER button.
2. **Suspended** displays on line 1 of the LCD panel. Press ENTER to enter the menu system.
3. **Maintenance** displays on line 3 of the LCD panel. Press ENTER to enter the **Maintenance** menu.
4. **Cleaning Card** displays on line 3 of the LCD panel. Press ENTER to enter the **Cleaning Card** menu.
5. **Isopropanol** displays on line 3 of the LCD panel. Press the down arrow.

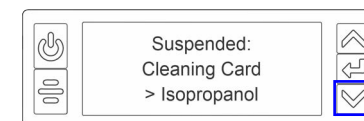
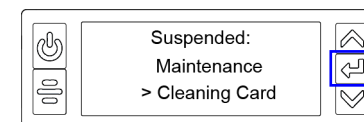
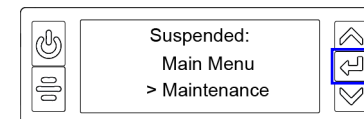

6. **Adhesive** displays on line 3 of the LCD panel. Press ENTER to select the adhesive cleaning card.



7. **Start** displays on line 2 of the LCD panel. Press ENTER to start the cleaning process.



8. The **Insert cleaning card** message displays on the LCD panel. Press the USER button to start the cleaning cycle.

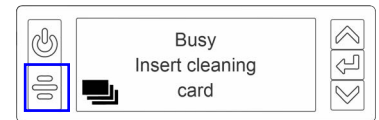

The printer moves the card through the printer several times. The card then moves into the vertical transport and cleans the rollers located there.

At the end of the cleaning cycle, the adhesive cleaning card is ejected into the printer reject tray (RT1).



When you clean a system with an ES1 Emboss Module, the adhesive cleaning card is ejected into the printer reject tray. The cleaning card does not travel into the embosser.

9. Continue with [“Prepare the Printer for Use”](#).

Prepare the Printer for Use

1. Remove the used cleaning card.
 - a. Unlock the printer and open the printer access door.
 - b. Remove the used cleaning card and any rejected cards from the printer reject tray (RT1). Refer to [“Empty the Printer Reject Tray”](#) on page 56.
2. Install a new cleaning sleeve. Refer to [“Replace the Cleaning Sleeve”](#) on page 33.
3. Install new ink ribbon and retransfer film.
 - a. Load new ink ribbon and retransfer film on the cartridges. Refer to [“Replace the Ink Ribbon”](#) on page 31 and [“Replace the Retransfer Film”](#) on page 35 for more information.
 - b. Replace the supply cartridges in the printer and close the printer access door.
4. Replace the cards in the input hopper of a single-hopper printer, or the H2 cartridge of a multi-hopper printer. Refer to [“Load Cards”](#) on page 28.
5. Lock the printer.

6. Press the USER button to return the printer to **Ready** and make it available to print cards again.
7. Discard the used cleaning card and cleaning sleeve.



HINTS & TIPS

- Use each cleaning card one time only.
- Replace the cleaning sleeve, as needed. Refer to the [“Printer Cleaning Schedule”](#) on page 42 for the replacement schedule.



If the card light is blinking amber and there are cards in the input hopper, the printer’s configured cleaning count has been reached and it is time to clean the printer. The number of cards between cleaning is set in the Printer Manager **FrontPanel** settings. Refer to the printer’s *Installation and Administrator’s Guide* for complete information about using Printer Manager.

Clean the Printhead

Clean the printhead each time you change the ink ribbon, or in the following situations:

- There are unprinted lines on the finished card. This may indicate dirt or contaminants on the printhead.
- The printhead is touched accidentally. Oils from hands can affect print quality and damage the printhead.

Use the following items to clean the printhead.

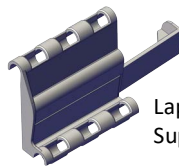

Lapping Stick Support

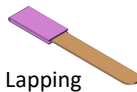

Lapping Stick



Cleaning Swab

1. Prepare the printer.
 - a. Power off the printer.
 - b. Unlock the printer and open the printer access door.
 - c. Remove the ink ribbon (C1) and retransfer film (C2) cartridges.

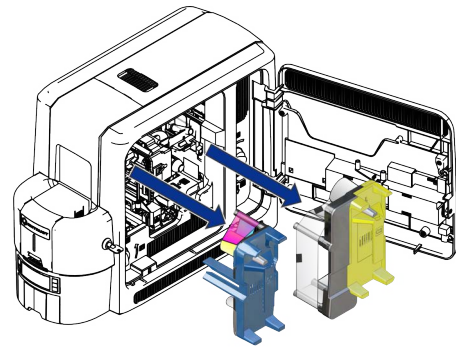

2. Insert the lapping stick support into the printer. The support tool fits over the guideposts and slides into the printer.

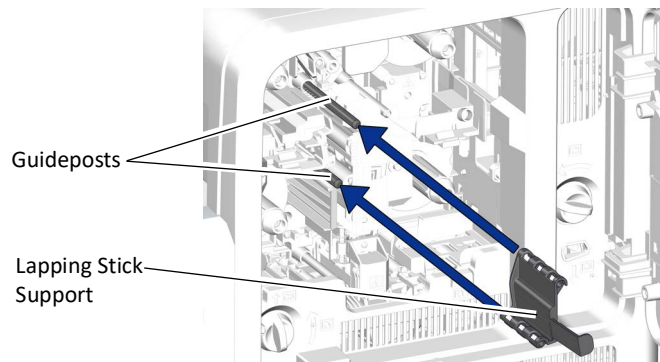

3. Clean the printhead with the lapping stick.



Do not remove the pink lapping paper from the lapping stick.

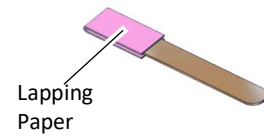

- a. Insert the lapping stick into the lower portion of the support tool. Slide it in until it stops.

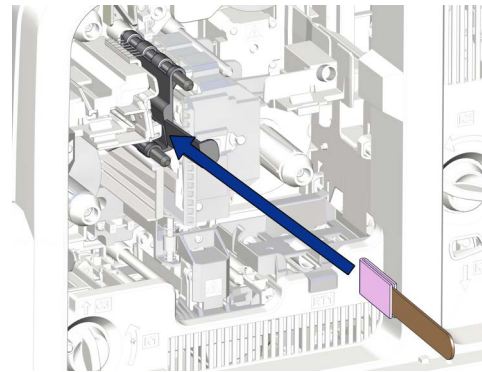

- b. Move the lapping stick back and forth 3 times to clean the printhead.

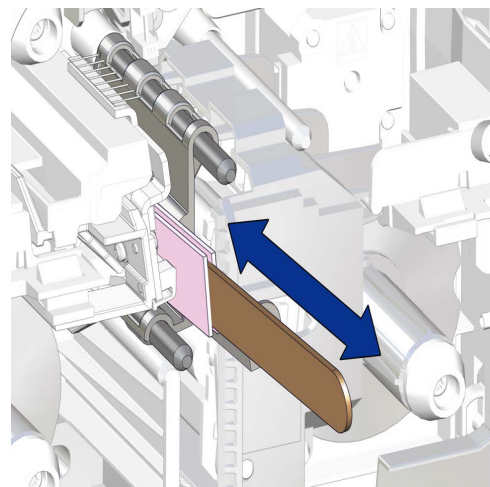

- c. Remove the lapping stick from the support tool.



You can use the lapping stick twice, one cleaning per side. Store the lapping stick after the first use.

4. Clean the printhead with the cleaning swab.

- a. Insert the cleaning swab into the support tool. Center the swab as shown in the illustration (or toward the top of the support tool handle).
- b. Move the cleaning swab back and forth 3 times to remove any remaining debris from the printhead area.

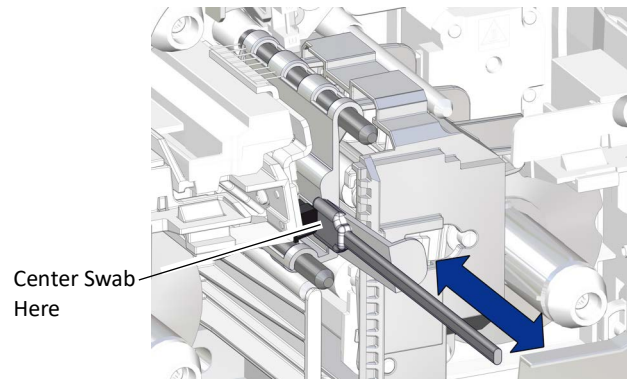

- c. Remove the cleaning swab from the support tool.

5. Remove the support tool from the printer.

 Do not discard the lapping stick support tool. Retain it for future cleaning use.

6. Prepare the printer for use.

- a. Replace the ink ribbon and retransfer film cartridges and close the printer access door.
- b. Power on the printer.

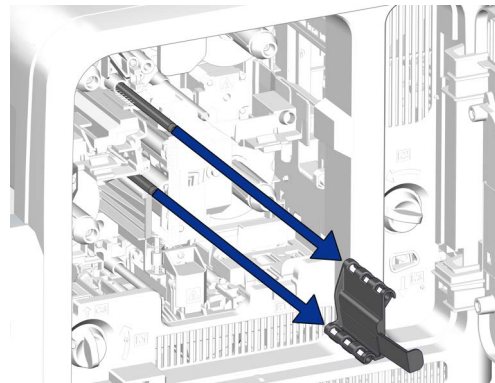

7. Print one or more test cards to verify the print quality.

HINTS & TIPS

- Use only the lapping stick and cleaning swab to clean the printhead. Other materials can stick to the printhead and cause damage.
- Discard the lapping stick after the second use.
- Use the cleaning swab one time only. Discard the swab after cleaning the printhead.

Clean the Printhead Cam Rollers

Use the adhesive cleaning card to clean the printhead cam rollers. Refer to the “[Printer Cleaning Schedule](#)” on [page 42](#) for information about when to clean the cam rollers.

1. Power off the printer, if necessary.
2. Unlock the access door lock and open the printer access door.
3. Remove the retransfer film cartridge (C2) from the printer.

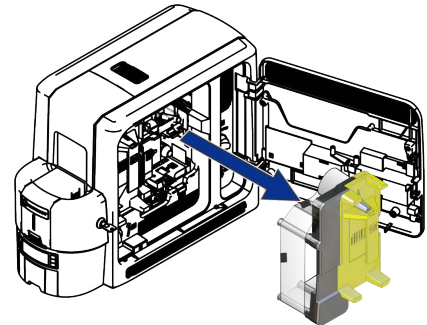

4. Peel off the center and both side strips from one side of the adhesive cleaning card.

Peel Off Center and Both Side Strips

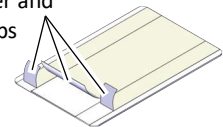

5. Insert the cleaning card into the printer between the retransfer cartridge guidepost and the rollers. Make sure that the adhesive side of the card faces to the right and touches the rollers.

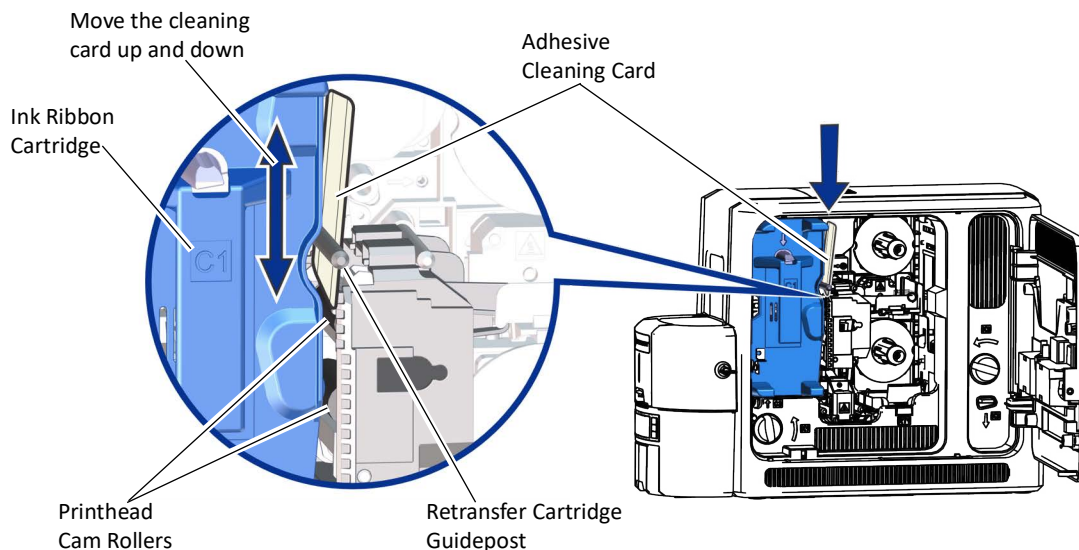

6. Move the cleaning card up and down along the rollers to remove debris.
7. Replace the retransfer film cartridge and close and lock the printer.
8. Discard the used cleaning card.

Empty the Printer Reject Tray

The printer places rejected cards (unfinished cards or cards that were not processed properly) in the reject tray. Empty the reject tray whenever the retransfer film is replaced, or more often depending on your procedures. Error message 242, "RT1 reject tray full," displays on the LCD panel when the reject tray is full.

1. Unlock the printer and open the printer access door.
2. Remove the retransfer film cartridge from the printer.

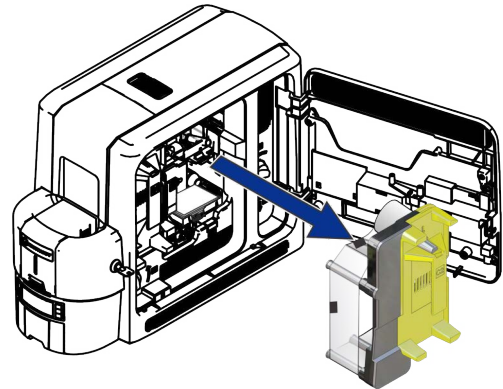

3. Remove the rejected cards from the reject tray.



You do not need to remove the reject tray from the printer. You can access the cards in the tray when the retransfer cartridge is removed.

4. Replace the retransfer film cartridge in the printer.
5. Close the printer access door and lock the printer.

Follow your organization's procedures to track the cards removed and to dispose of them properly.

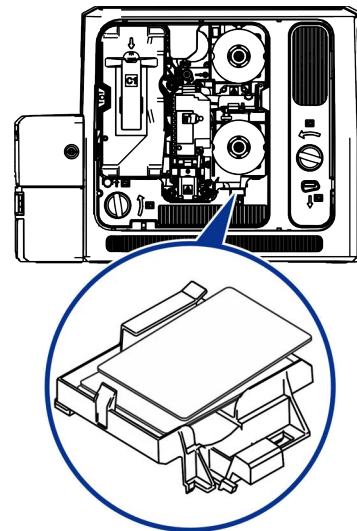

If your system includes an embosser, the printer reject tray is not used. Cards are placed in the embosser reject tray. Refer to the *ES1 Emboss Module User's Guide*.



Chapter 6: Troubleshooting



This chapter provides information to help you respond to card printer messages. It also explains how to clear card jams and how to recover from other errors.

This section helps you identify and fix basic issues that can occur during printing. Also refer to your Instant Financial Issuance documentation for additional troubleshooting information.

The section starts with an overview of card production and printer issues you may encounter:

- [Locate a Problem Within the Card Production System on page 58](#)
- [Locate a Problem with Basic Printer Functions on page 59](#)

This section also describes troubleshooting for the following:

- [Installation Problems on page 60](#)
- [Card Appearance on page 61](#)
- [Magnetic Stripe Troubleshooting on page 65](#)
- [Printer Card Jams on page 67](#)
- [Repair a Broken Ink Ribbon or Retransfer Film on page 71](#)
- [Messages and Conditions on page 72](#)
- [Respond to Messages on page 73](#)

Locate a Problem Within the Card Production System

For typical components of the system, refer to [“Printer Overview”](#) on [page 15](#). If any one of the following components does not work properly, printing cards can be affected.

- Card production software

Card production software formats the types of data used to print cards. Make sure that the card production software features you use work with your printer.

- Other components of the system

A system may include capture devices, such as a signature capture pad or PIN pad. The proper use and maintenance of these components is important to the quality of cards you produce.

Locate a Problem with Basic Printer Functions

If the system is not working as expected, follow these steps in the order listed to isolate the source of the problem before you contact your service provider.

1. Make sure that the power cord is plugged in and the printer is powered on.
2. Does the printer power on and display **Ready** on the front panel within one minute?
 - If the printer powers on correctly, continue to step 3.
 - If the printer powers on, but **Improper Shutdown** displays on the LCD panel, press the **USER** button for approximately two seconds. **Ready** should display.
 - If the printer powers on but does not display **Ready**, the printer is not working properly. Request service for the printer.
 - If the printer does not power on, make sure that the printer power supply is working properly. A light on the power supply indicates that it is functioning.
 - ◆ If the power supply is working properly, request service for the printer from your system administrator.
 - ◆ If the power supply is not functioning, replace it and begin with step 1.
3. Print a test card. Refer to [“Print a Test Card”](#) on [page 26](#) for more information.
 - If the test card prints, the printer is working correctly. Continue to step 4.
 - If the test card does not print, the printer is not working correctly. Request service for the printer.
4. Connect the printer data cable, if necessary.

5. Print a card using your card production software.
 - If the card prints, your software is working successfully with the printer. Troubleshoot the card design, if necessary.
 - If the card does not print, check the following:
 - ◆ Is the correct printer selected in the Print Setup or Print dialog box of the application?
 - ◆ If the printer produced a blank card, review the page size or other settings.

If the card causes an error, the card might have a type of data the printer does not support.

Installation Problems

This section describes issues that prevent a successful installation and provides recommended solutions to those issues.

Problem	Solution
The network cable is loose.	Reconnect the data cable to the network port and the printer. Restart the printer.
The printer displays Ready on the LCD panel, but it is not available.	Follow your network troubleshooting procedures to isolate and test each component of the computer-to-printer communication link. Suggestions: <ul style="list-style-type: none"> ● Verify the computer-to-network connection by accessing a network resource, such as a network drive. ● The network administrator can test communication between a server and the printer. ● Make sure that the user is logged on to the network.
The printer is not configured with the correct network address.	Make sure that the server name or IP address is entered in the Port Settings or Configure Port dialog box on the computer. For more information about retrieving the printer's IP address, refer to "Retrieve the Printer's Network IP Address" on page 21 . Make sure that Ready displays on the printer's LCD panel.
Multi-hopper does not turn on or operate.	Check the multi-hopper configuration label to confirm that N3 is in the configuration code to indicate that is compatible with the RSx series printer. Refer to "Multi-Hopper Configuration Label" on page 13 .

Card Appearance

Card appearance problems can be caused by many different factors. Click the link below that best describes the card appearance issue on the printed card.

- [Something did not print](#)
- [Print quality concerns](#) on [page 62](#)

Tools for Troubleshooting

The tools for troubleshooting a problem include the supplies and equipment you use to print cards:

- Blank cards to print, used at several stages of troubleshooting
- Ink ribbon and retransfer film
- Printer cleaning supplies

Something did not print

Problem	Probable Cause	Solution
Nothing printed on the card.	The ink ribbon or retransfer film is loaded incorrectly.	Remove the supply and install it correctly.
	The page size was not set to the proper size.	Use your card production application to select the correct printer page size.

Print quality concerns

Problem	Probable Cause	Solution
One or more color or white streaks appear on the card.	Dust or debris on the printhead.	<ul style="list-style-type: none"> • Try printing another card as the dust may no longer be on the printhead. • Clean the printhead. Refer to “Clean the Printhead” on page 52. • If the printhead is damaged, contact your service provider.
Non-repeating color dots appear on multiple printed cards.	Dust or debris on the ink ribbon or retransfer film.	Advance the ink ribbon or retransfer film, or install new supplies.
Repeating color dots appear on multiple printed cards.	Dust or debris on the cam rollers located opposite the printhead.	Clean the printhead cam rollers with an adhesive cleaning card. Refer to “Clean the Printhead Cam Rollers” on page 55.
One color panel is not aligned correctly with other color panels.	The ink ribbon or retransfer film is slipping.	Contact your service provider to adjust the tension on the ink ribbon or retransfer film.
Card with darkly colored areas are not printing properly.	The card includes very dark areas.	<ul style="list-style-type: none"> • If possible, change the design to use smaller areas of dark color. • Use a different color ink ribbon. Contact your service provider for more information.
Color printing is darker than intended.	The black (K) panel of the ink ribbon is used to darken other colors, in addition to printing any black elements. The black ink is beneath the color (YMC) pigments when they are placed on the card.	Refer to “Elements of Card Design” in the printer’s <i>Installation and Administrator’s Guide</i> for suggestions and printing guidelines.

Problem	Probable Cause	Solution
Part of the printed image is discolored or blurred.	The cards have fingerprints or debris on them.	<ul style="list-style-type: none"> • Make sure that cards are clean. Handle cards carefully. Refer to “Card Quality Guidelines” in the printer’s <i>Installation and Administrator’s Guide</i>. • Use cards that meet the requirements for the printer. Refer to “Cards” in the printer’s <i>Installation and Administrator’s Guide</i>.
	The transport rollers are dirty.	Clean the printer and replace the cleaning sleeve. Refer to the “ Printer Cleaning Schedule ” on page 42 and “ Replace the Cleaning Sleeve ” on page 33.
	The printhead is dirty.	Clean the printhead. Refer to “ Clean the Printhead ” on page 52.
The printed card has small unprinted areas.	Unprinted cards have scratches.	Handle cards carefully. Refer to “Card Quality Guidelines” in the printer’s <i>Installation and Administrator’s Guide</i> .
	The transport rollers are dirty.	Clean the printer. Refer to the “ Printer Cleaning Schedule ” on page 42.
Wrinkles appear on the card.	The supplies are wrinkled.	<ul style="list-style-type: none"> • Check the ink ribbon and retransfer film. If either is wrinkled, advance the supply in the cartridge to an unwrinkled section. • Replace the supplies, if necessary.
	The printer firmware is not current.	Update the printer to the current firmware version. Firmware updates often contain fixes for common printing issues.

Problem	Probable Cause	Solution
The card has trapped dust or debris.	Particles from the retransfer process (flash) can accumulate inside the printer.	Clean the printer and printhead cam rollers. Refer to the “Printer Cleaning Schedule” on page 42 and “Clean the Printhead Cam Rollers” on page 55. Note: You may need to run multiple cleaning cycles to remove all particles from the printer.
	The card stock may have embedded particles.	Check your cards for defects. Replace the card stock, if necessary.
Retransfer material appears on the magnetic stripe, signature panel, or smart card chip.	Blocking regions are not set up correctly.	<ul style="list-style-type: none"> • Make sure that the blocking regions for card features are set up properly. Use the blocking regions in your card design software, or define custom regions. Refer to <i>“Non-Printing Areas”</i> in the printer’s <i>Installation and Administrator’s Guide</i>. Note: The location and dimensions of the blocking regions can vary depending on the card stock you use. • Clean the printer. Refer to the “Printer Cleaning Schedule” on page 42.

Magnetic Stripe Troubleshooting

The printer uses the coercivity set using the LCD panel or in Printer Manager, and the data format set using Printer Manager.

Problem	Solution
Cards are not loaded correctly.	Load ISO cards with the magnetic stripe (back side) facing down and to the right. Refer to “Load Cards” on page 28.
Cards do not have a magnetic stripe.	Load magnetic stripe cards in the input hopper. If the cards have a magnetic stripe, check the quality of the cards. Change card stock, if needed.
The card has dirt or damage on the magnetic stripe.	Encode and send a new card to print. If an error message indicates a magnetic stripe problem, run a cleaning card to clean the magnetic stripe head. Refer to the “Printer Cleaning Schedule” on page 42.
The magnetic stripe on the card is low-coercivity material and the High Coercivity setting is selected.	To use the cards you have, select low-coercivity encoding. Refer to “MagStripeGeneral” in the printer’s <i>Installation and Administrator’s Guide</i> for more information. To encode with high coercivity, obtain cards manufactured for high-coercivity encoding.
The magnetic stripe on the card is high-coercivity material and the Low Coercivity setting is selected.	To use the cards you have, select high-coercivity encoding. Refer to “MagStripeGeneral” in the printer’s <i>Installation and Administrator’s Guide</i> for more information. To encode with low coercivity, obtain cards manufactured for low-coercivity encoding.
The data for this job includes characters not allowed by the magnetic stripe format selected for the track.	Cancel the current print job. Make sure that you know which characters are allowed on the track. Change the data to be encoded, and resend the print job. Refer to “Magnetic Stripe Design” in the printer’s <i>Installation and Administrator’s Guide</i> for more information.

Problem	Solution
<p>The magnetic stripe data was sent in an encoding format not supported by the track.</p>	<p>Review the encoding format setting for the tracks in Printer Manager. Refer to “MagStripeGeneral” in the printer’s <i>Installation and Administrator’s Guide</i> for more information. Make sure that the application is using the selected encoding format for the track.</p> <p>If the application and track are set to the same format, and the error message displays repeatedly, contact the application provider for assistance.</p>
<p>The application sent track data for a track not supported by the magnetic stripe module.</p>	<p>Verify the type of magnetic stripe option in the printer.</p> <p>If the printer label indicates a 3-track ISO module, you can send data for tracks 1, 2, and 3.</p> <p>If the printer label indicates a single-track JIS module, you can send data for track 1.</p> <p>The magnetic stripe option and cards must be capable of accepting and encoding each track of data sent by the card production software.</p>

Advanced Troubleshooting Tools

Printer Manager provides access to card design settings and additional troubleshooting tools. Printer Manager also allows you to perform advanced troubleshooting with the guidance of your service provider. Refer to the “Printer Manager” section in the printer’s *Installation and Administrator’s Guide* for more information.

Printer Card Jams

A card jam occurs when the card does not reach the proper position for the next action, such as printing or ejecting the card. The error condition that displays on the LCD helps you identify the location of the card jam.

Clear a Card Jam in the K1 Horizontal Transport

If message 234: “K1 transport card jam” displays, you usually can resolve the error by pressing the USER button to move the card into the reject tray. If the error persists, do the following to remove the card from the printer.

Single-Hopper Printer

1. Unlock the printer and open the printer access door.
2. Remove the retransfer film cartridge.

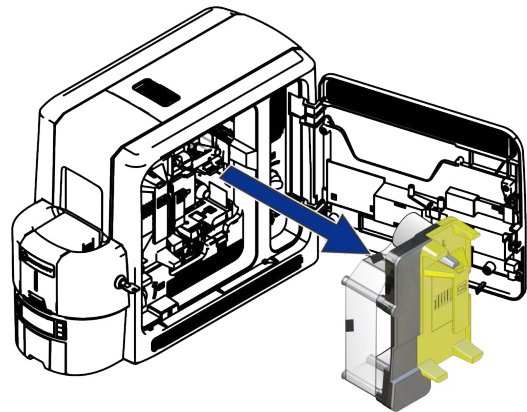

3. Turn the K1 manual advance knob counterclockwise to move the jammed card into the output hopper.
4. Remove the card through the output hopper.
5. Replace the retransfer film cartridge and close the printer access door.
6. Lock the printer.
7. Press the USER button on the printer to clear the message.

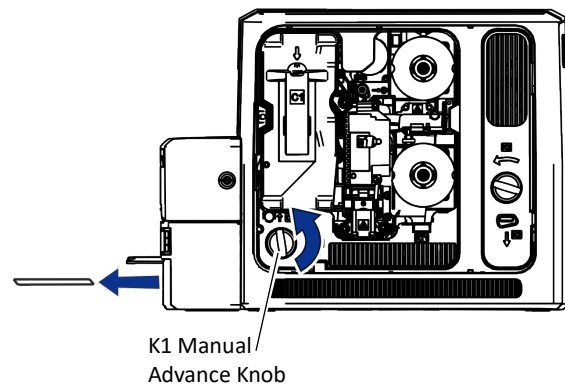

Multi-Hopper Printer

1. Unlock the printer and open the printer access door.
2. Remove the ink ribbon and retransfer film cartridges.
3. Locate the card in the printer. Turn the K1 manual advance knob if necessary to gain access to the card.
4. Reach into the printer and remove the card.
5. Replace the ink ribbon and retransfer film cartridges.
6. Close the printer access door and lock the printer.
7. Press the USER button on the printer to clear the message.

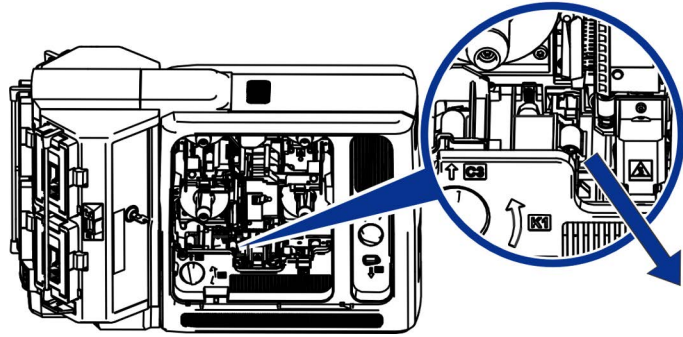

HINTS & TIPS

Check the ink ribbon and retransfer film to make sure that they are not broken. Refer to [“Repair a Broken Ink Ribbon or Retransfer Film”](#) on [page 71](#).

Clear a Card Jam in the K2 Vertical Transport

The vertical transport houses the magnetic stripe module and smart card reader. If message 235: “K2 transport card jam” displays, you usually can resolve the error by pressing the USER button to move the card into the reject tray. If the error persists, do the following to remove the card from the printer.

1. Unlock the printer and open the printer access door.
2. Press the K3 rear access door release to open the rear access door.
3. Turn the K2 manual advance knob counterclockwise to move the jammed card inside the vertical transport until it is accessible through the rear access door.

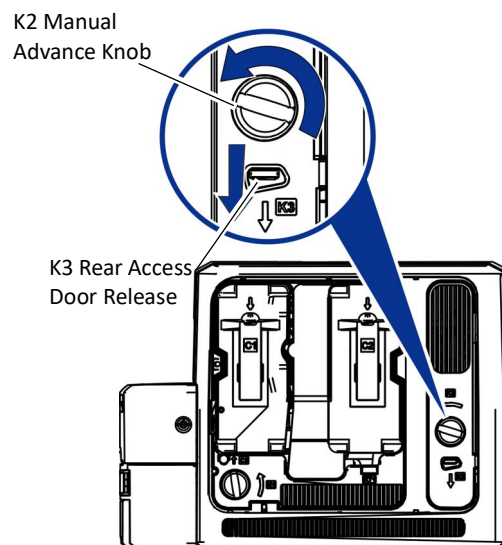

4. Remove the card through the rear access door.
5. Close the rear access door.
6. Close the printer access door and lock the printer.
7. Press the USER button on the printer to clear the message.

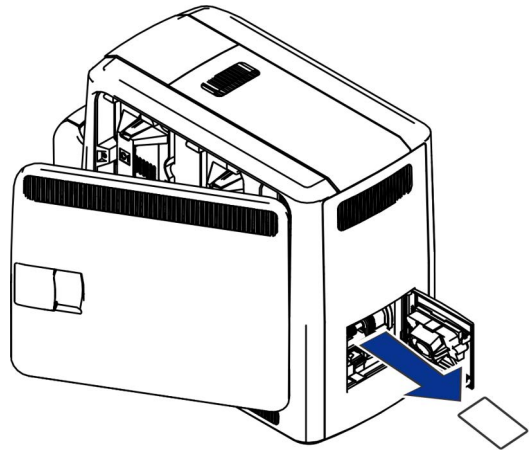

Clear a Card Jam in the Flipper Module

Do the following if message 236: "Flipper module rotate error" displays.

1. Unlock the printer and open the printer access door.
2. Press the K3 rear access door release to open the rear access door.

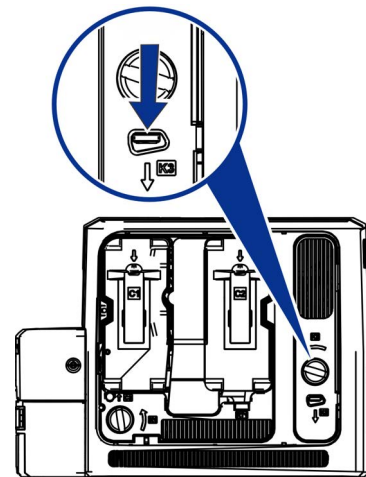

3. Reach into the flipper module and rotate it until you can access the card.
4. Remove the card through the rear access door.
5. Close the rear access door.
6. Close the printer access door and lock the printer.
7. Press the USER button on the printer to clear the message.

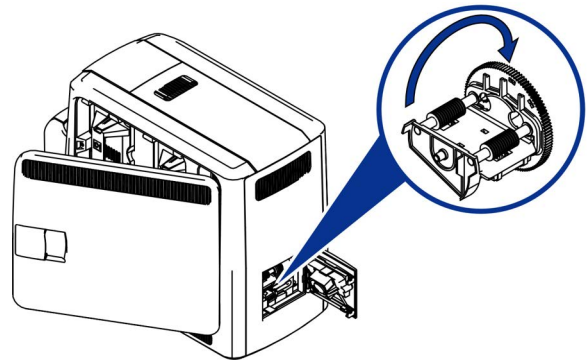

Repair a Broken Ink Ribbon or Retransfer Film

If the ink ribbon or retransfer film breaks, one of the following messages displays on the printer LCD:

- **240, C1 supply error** There is a problem with the ink ribbon.
- **175, C2 supply error** There is a problem with the retransfer film.

1. Unlock the printer and open the printer access door.
2. Remove the cartridge with the damaged supply from the printer.

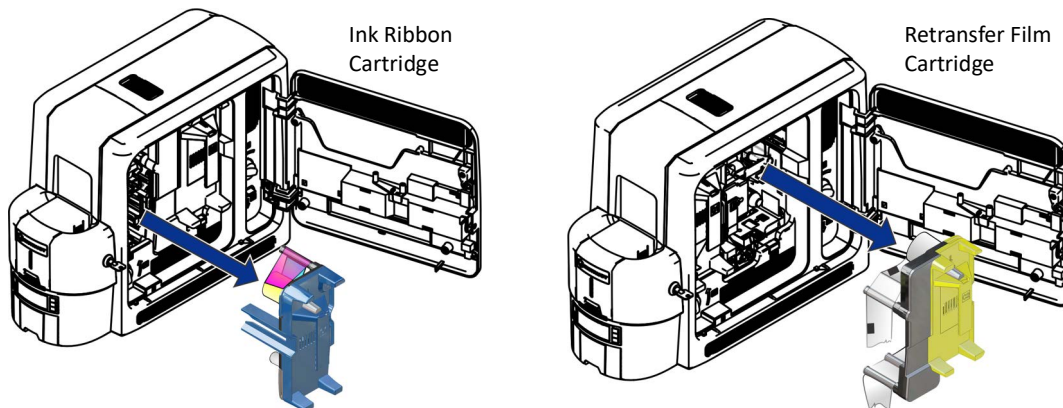

3. Trim the ends of the broken ribbon or film evenly.



Do not remove the used ink ribbon or retransfer film from the take-up spool. Removing, and then reinstalling, the supply on the take-up spool may cause printing issues.

4. Align the ends of the broken media evenly and apply adhesive tape to secure them.

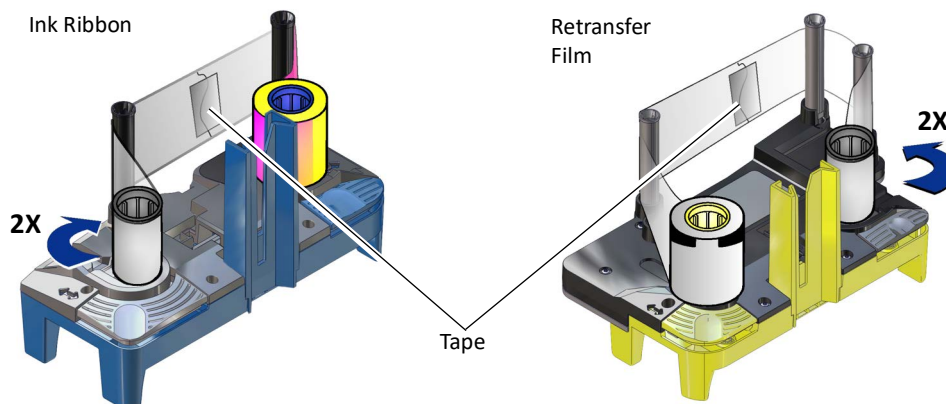

5. Turn the take-up spool until the mended portion is wound onto the spool two or three turns.

Make sure that the ink ribbon or retransfer film is routed as shown on the cartridge and that there are no wrinkles in the supply.

6. Remove any slack in the ink ribbon or retransfer film.
7. Reinstall the cartridge into the printer until it clicks into position.
8. Close the printer access door and lock the printer.

Messages and Conditions

When the system cannot process the card sent, it issues a condition. Conditions display on the LCD panel on the front panel of the printer. Refer to the following for more information:

- [Messages on the Printer LCD](#)
- [Messages from Printer Manager on page 73](#)
- [Other Messages on page 73](#)

Messages on the Printer LCD

All messages are associated with a print job. The printer issues messages that focus on recovering from problems.

- The printer displays a message number and a short description for each message.
- If asked by Technical Support, press the down arrow to display a service code that further isolates the cause of the error.
- If more than one message was issued, the next message displays after you correct the problem and press the USER button.
- The LED light bar on the printer flashes while messages display on the LCD panel.

Messages from Printer Manager

Printer Manager issues messages that display in the browser window. Follow the instructions in the message to continue working with the printer. Refer to “Printer Manager” in your printer’s *Installation and Administrator’s Guide*.

Other Messages

- The card production application you use also may issue messages.
- Other printers can cause messages if more than one model of card printer is installed.
- The Card Printer Driver can issue a message if a print job is sent to the printer using the driver. Refer to “[Driver-Only Message](#)” on [page 87](#).

Respond to Messages

Messages display on the printer front panel LCD to identify various operational conditions and errors of card production on the system. You can respond to messages using the printer front panel buttons.



The messages that display are determined by the printer model and the options installed in the printer. The messages described in the following sections may not display on all printers.

Important! Always discard damaged, rejected, or partially printed cards according to your organization’s established procedures.

The following messages display on the printer LCD panel. Use the recovery instructions to respond to the message.

- [Printer Messages](#) on [page 74](#)
- [Driver-Only Message](#) on [page 87](#)

Printer Messages

The following messages indicate a condition in the printer.

Close and lock doors

A secure door is physically unlocked on the system.

1. Gently try to open all secure doors on the system.
2. Close any open door and lock the printer using the key.

100: Request not supported

The printer does not support the personalization being requested for the card. The card will be canceled.

Change the card data to match the printer's options and settings, or print to a printer that is configured to support the personalization being requested.

Press the USER button on the printer to clear the message.

Send the card again.

103: Printer problem

The printer had an error. The card will be canceled.

1. Press the printer POWER button to power off the printer.
2. Press the POWER button again to power on the printer.

104: Critical problem

The printer had a serious error. The card will be canceled.

1. Press the printer POWER button to power off the printer.
2. Request service.

The system must remain powered off.

105: Magstripe data error

The printer failed to verify that the correct magnetic stripe data was written on the card.

1. Make sure that you are using magnetic stripe cards that match the printer settings.
2. Make sure that the cards are placed in the printer correctly.

Press the USER button on the printer to clear the message and send the card to print again.

HINTS & TIPS

- The card might have been loaded into the input hopper the wrong way. A diagram inside the input hopper shows the correct orientation.
- The card might not have a magnetic stripe.

106: Magstripe data not found

The printer did not find magnetic stripe data on card.

1. Make sure that you are using magnetic stripe cards that match the printer settings.
2. Make sure that the cards are placed in the printer correctly.

Press the USER button on the printer to clear the message and send the card to print again.

HINTS & TIPS

- The card might not match printer settings or the data sent.
- Ask the system administrator to verify that the card, the data, and the printer settings match.

107: Magstripe read data error

The printer failed to read the magnetic stripe data from the card. The card will be canceled.

1. Make sure that you are using magnetic stripe cards that match the printer settings.
2. Make sure that the cards are placed in the printer correctly.

Press the USER button on the printer to clear the message. Send the card job to the printer again.

HINTS & TIPS

- The data might use a different format than the current printer setting.
- Ask the system administrator to verify that the card, data, and printer settings match.

108: Magstripe read no data

The printer did not find any magnetic stripe data on the card. The card will be canceled.

1. Make sure that you are using magnetic stripe cards that match the printer settings.
2. Make sure that the cards are placed in the printer correctly.

Press the USER button on the printer to clear the message.

HINTS & TIPS

- The card might have been turned the wrong way. A diagram inside the input hopper shows the correct orientation.
- The card might not have a magnetic stripe.

111: Card not picked

The printer did not pick a card. To complete the current card, open the input hopper, add or reposition the cards, and close the hopper.

Press the USER button on the printer to clear the message.

112: Card hopper empty

The printer did not detect cards in the input hopper.

Add cards to the input hopper.

Press the USER button on the printer to clear the message.

113: Close cover to continue

The printer cover is open. Close the cover to continue.

Press the USER button on the printer to clear the message.

HINTS & TIPS

- Make sure that the ink ribbon and retransfer cartridges are installed properly, if necessary.
- All access doors must be closed to process cards. Unlock, open, and close all printer doors to make sure they are closed completely.
- Lock the system.

114: Cover opened during job

The printer cover was opened while printing.

Close the printer cover completely.

Press the USER button on the printer to clear the message.

HINTS & TIPS

- Make sure that the ink ribbon and retransfer cartridges are installed properly.
- All access doors must be closed to process cards. Unlock, open, and close all printer doors to make sure they are closed completely.
- Lock the system.

116: Magstripe not available

The printer does not have a magnetic stripe option. The card will be canceled.

Remove magnetic stripe data from the card or use a printer that has a magnetic stripe option installed.

Press the USER button on the printer to clear the message.

HINTS & TIPS

- Look at the printer configuration label inside the printer component. If the label includes an "M," the system has a magnetic stripe option that is not working. Request service.
- To process the card without magnetic stripe processing, remove the magnetic stripe data from the card design and send it again.

117: Reader not available

The printer does not support the personalization being requested for the card. The card will be canceled.

Change the card data to match the printer's options and settings or print to a printer that is configured to support the personalization being requested.

Press the USER button on the printer to clear the message.

HINTS & TIPS

The printer component does not have a reader option. Remove the reader request from the card and send it again.

120: User paused the printer

The printer was paused while printing.

To complete the current card press the printer's USER button.

HINTS & TIPS

- If the user pressed the button for several seconds, the card has been canceled.
- If this message occurs often, ask your system administrator to set the button sensitivity to a lower value.

122: Magstripe format problem

The magnetic stripe data sent does not match the format set in the printer. The card will be canceled.

Press the USER button on the printer to clear the message.

149: Option not installed

The printer does not support the personalization being requested for the card. The card will be canceled.

Change the card data to match the printer's options and settings, or print to a printer that is configured to support the personalization being requested.

Press the USER button on the printer to clear the message.

150: Print while unlocked

The printer is unlocked. The card will be canceled.

Make sure that all access doors are closed securely and locked.

151: Failed to lock

An attempt to lock the printer failed. The card will be canceled.

1. Make sure that all access doors are closed securely.
2. Try locking the printer again.

HINTS & TIPS

Make sure that the reject tray is installed properly before locking the printer.152: Insert new card side 2 up

1. Turn a new card over end to end so side 2 is facing up.
2. Insert the card in the printer.
3. If the card is not immediately picked, press the printer's USER button.

153: Insert same card side 2 up

1. Take the card from the printer and turn it over end to end so side 2 is facing up.
2. Insert the card in the printer.
3. If the card is not immediately picked, press the printer's USER button.

166: C2 supply out or missing

The C2 retransfer film is missing or out of material.

1. Open the printer access door and remove the C2 retransfer film cartridge.
2. Replace the retransfer film.
3. Replace the C2 retransfer film cartridge.
4. Close the printer access door.

Press the USER button on the printer to clear the message.

HINTS & TIPS

Refer to [“Replace the Retransfer Film”](#) on [page 35](#) for more information.

167: C2 supply not identified

The printer cannot use the C2 retransfer film installed. The card will be canceled.

Use a supply designed for this printer.

Press the USER button on the printer to clear the message.

168: C2 supply not supported

The printer model cannot use the C2 retransfer film installed. The card will be canceled.

Use a supply designed for this printer model.

Press the USER button on the printer to clear the message.

170: Insert new card side 1 up

1. Insert a new card in the printer with side 1 facing up.
2. If the card is not immediately picked, press the printer's USER button.

171: Insert same card side 1 up

1. Take the card from the printer and turn it over end to end so side 1 is facing up.
2. Insert the card in the printer.
3. If the card is not immediately picked, press the printer's User button.

172: Insert cleaning card

1. Insert cleaning card.
2. If the card is not immediately picked, press the printer's USER button.

173: Improper shutdown

Always use the POWER button to power off the printer.

Press and hold the USER button to set the printer to **Ready**.

Click **OK** on the PC to clear the message.

HINTS & TIPS

The system was shut down incorrectly or lost power.

175: C2 supply error

The C2 retransfer film has encountered an error.

1. Open the printer access door and remove the C2 retransfer film cartridge.
2. Reposition, repair, or replace the supply and advance the repaired area one full turn.
3. Replace the C2 retransfer film cartridge.
4. Close the printer access door.

Press the USER button on the printer to clear the message.

HINTS & TIPS

Refer to [“Replace the Retransfer Film”](#) on page 35 or [“Repair a Broken Ink Ribbon or Retransfer Film”](#) on page 71 for more information.

176: C2 supply type error

The C1 ink ribbon and C2 retransfer film are not compatible. Replace one or both with known compatible supplies.

Ink ribbons with a primer (P) panel and those without a primer panel must have a compatible retransfer film installed. Make sure that the ink ribbon and retransfer film installed in the printer are compatible.

Press the USER button on the printer to clear the message. On the PC, click **Retry**, or click **Cancel** to cancel the card.

222: Firmware version mismatch

The printer and attached component firmware versions are not compatible. The system cannot process cards until the firmware has been updated.

Update both the printer and component to the latest firmware versions.

HINTS & TIPS

After the firmware update program completes, shut down and restart the system to complete the component firmware update.

228: C1 printhead error

The printer has encountered a critical error. The card will be canceled.

1. Press the printer POWER button to power off the system.
2. Request service. The system must remain powered off.

229: C2 heat sensor error

The C2 retransfer heat sensor has encountered a critical error. The card will be canceled.

1. Press the printer POWER button to power off the system.
2. Request service. The system must remain powered off.

230: C2 heater error

The C2 retransfer heater has encountered a critical error. The card will be canceled.

1. Press the printer POWER button to power off the system.
2. Request service. The system must remain powered off.

231: C2 heated roller motion error

The C2 retransfer heated roller has encountered a critical error. The card will be canceled.

1. Press the printer POWER button to power off the system.
2. Request service. The system must remain powered off.

232: Retransfer debow error

The printer has encountered an error in the retransfer debow area. The card will be canceled.

1. Press the USER button to move the card into the reject tray and clear the error.
2. If the error occurs again, open the printer access door and look for a card in the debow area.
3. Turn the K1 manual advance knob to move the card out of the printer.
4. If the problem continues to occur, request service.

233: Smart card contact fail

There is a critical error with the smart card contact. The card will be canceled.

1. Press the USER button to move the card into the reject tray and clear the error.
2. Send the card job to the printer again.

234: K1 transport card jam

The card did not reach the required position on the K1 horizontal transport. The card will be canceled.

1. Press the USER button to move the card into the reject tray and clear the error.
2. If the error occurs again, open the printer access door and remove the C2 retransfer film cartridge.
3. Turn the K1 manual advance knob counterclockwise to move the card to the output hopper.
4. Remove the card from the output hopper.
5. Replace the retransfer film cartridge.
6. Close the printer access door.

235: K2 transport card jam

The card did not reach the required position on the K2 vertical transport. The card will be canceled.

1. Press the USER button to move the card into the reject tray and clear the error.
2. If the error occurs again, open the printer access door.
3. Press the K3 rear access door release to open the rear access door.
4. Turn the K2 manual advance knob counterclockwise to move the card until it is accessible.
5. Remove the card through the rear access door.
6. Close the printer access doors.

236: Flipper module rotate error

The flipper did not reach the required position.

1. Open the printer access door.
2. Press the K3 rear access door release to open the rear access door.
3. Reach in and rotate the flipper module until the card is accessible.
4. Remove the card through the rear access door.
5. Close the rear access door and then close the printer access door.

Press the USER button to clear the message.

237: C1 supply out or missing

The C1 ink ribbon is missing or out of material.

1. Open the printer access door and remove the C1 ink ribbon cartridge.
2. Replace the ink ribbon.
3. Replace the ink ribbon cartridge.
4. Close the printer access door.

Press the USER button on the printer to clear the message.

HINTS & TIPS

Refer to [“Replace the Ink Ribbon”](#) on [page 31](#) for more information.

238: C1 supply not identified

The printer cannot use the C1 ink ribbon installed.

Use a supply designed for this printer.

Press the USER button on the printer to clear the message.

239: C1 supply not supported

The printer model cannot use the C1 ink ribbon installed.

Use a supply designed for this printer model.

Press the USER button on the printer to clear the message. 240: C1 supply error

The C1 ink ribbon has encountered an error.

1. Open the printer access door and remove the C1 ink ribbon cartridge.
2. Reposition, repair, or replace the ink ribbon and advance the repaired area one full turn.
3. Replace the ink ribbon cartridge.
4. Close the printer access door.

Press the USER button on the printer to clear the message.

HINTS & TIPS

Refer to [“Replace the Ink Ribbon”](#) on [page 31](#) or [“Repair a Broken Ink Ribbon or Retransfer Film”](#) on [page 71](#) for more information.

241: C1 supply type error

The C1 ink ribbon does not support an action requested by this print job.

Use a supply designed for this printer model.

Press the USER button on the printer to clear the message.

242: RT1 reject tray full

The reject tray is full.

1. Open the printer access door.
2. Remove the retransfer film cartridge.
3. Remove the rejected cards.
4. Replace the retransfer film cartridge.
5. Close the printer access door.

Press the USER button on the printer to clear the message.

243: Card lost

A card that is expected to be in the printer is no longer present. The card will be canceled and added to the Lost Cards count. Send the job to print again.

Press the USER button on the printer to clear the message.

245: Configuration error

The configuration is not compatible with the printer model. The printer cannot print cards until the configuration issue is corrected. Contact your service provider for assistance.

275: Multi-hopper error

The multi-hopper has encountered a critical error. The card will be canceled.

1. Press the printer POWER button to power off the printer.
2. Press the POWER button again to power on the printer.

If the error occurs again, request service.

276: Multi-hopper card jam

The multi-hopper did not move a card into the printer.

Press the USER button to clear the error. If a card was jammed, it is moved to the reject tray.

277: Multi-hopper pick error

The multi-hopper did not pick a card from the input hopper cartridge.

1. Unlock the multi-hopper.
2. Remove each cartridge and make sure that cards are loaded properly.
3. Make sure that the cartridges are installed correctly.
4. Check the exception slide.
5. Lock the multi-hopper.

Press the USER button to clear the error.

278: Insert cleaning card in H2

1. Unlock the multi-hopper.
2. Remove unused cards and insert the cleaning card in hopper 2.
3. Close and lock the multi-hopper.
4. Press the printer's USER button to pick the card.

Driver-Only Message

The following message is issued by the Card Printer Driver if you send a print job to the RS4 instant issuance system using the driver. The Card Printer Driver does not support the RS4 systems without the use of an upgrade kit. The message displays on the PC that sent the card print job. It does not display on the printer LCD.

518: Unable to print.

The driver does not support the printer you have selected. Contact your authorized service representative for assistance.

