



**ENTRUST**

## User's Guide

---

### **Card Lamination Module**

May 2024

528086-001, Rev. C

## Notice

Please do not attempt to operate or repair this equipment without adequate training. Any use, operation or repair you perform that is not in accordance with the information contained in this documentation is at your own risk.

## Trademark Acknowledgments

Entrust, Sigma and the hexagon design are trademarks, registered trademarks and/or service marks of the Entrust Corporation in the United States and other countries.

Datacard is a registered trademark and service mark of Entrust Corporation in the United States and other countries.

MasterCard is a registered trademark of MasterCard International Incorporated.

Visa is a registered trademark of Visa International Service Association.

All other product names are the property of their respective owners.

## Proprietary Notice

The design and information contained in these materials are protected by US and international copyright laws.

All drawings and information herein are the property of Entrust Corporation. All unauthorized use and reproduction is prohibited.

### **Entrust Corporation**

1187 Park Place  
Minneapolis, MN 55379  
Phone: 952-933-1223  
Fax: 952-933-7971  
[www.entrust.com](http://www.entrust.com)

© 2020-2024 Entrust Corporation. All rights reserved.

# Safety

The following basic safety tips are given to ensure safe installation, operation and maintenance of Datacard® equipment.

- Connect equipment to a grounded power source. Do not defeat or bypass the ground lead.
- Place the equipment on a stable surface (table) and ensure floors in the work area are dry and non-slip.
- Know the location of equipment branch circuit interrupters or circuit breakers and how to turn them on and off in case of emergency.
- Know the location of fire extinguishers and how to use them. ABC type extinguishers may be used on electrical fires.
- Know local procedures for first aid and emergency assistance at the customer facility.
- Use adequate lighting at the equipment location.
- Maintain the recommended temperature and humidity range in the equipment area.

## Safe Human Interface

- Use proper lifting techniques when moving or installing the equipment.
- Use standard electrostatic discharge (ESD) precautions when working on or near electrical circuits.
- Do not defeat or disconnect safety interlocks on covers.



**Warning:** To avoid a possible electric shock, always unplug the system before servicing.

## Liability

The WARNING and CAUTION labels have been placed on the equipment for your safety. Please do not attempt to operate or repair this equipment without adequate training. Any use, operation, or repair in contravention of this document is at your own risk.

## California Prop

**Warning:** This product contains chemicals, including lead, known to the State of California to cause cancer, and birth defects or other reproductive harm. *Wash hands after handling.*

For more information on this warning, refer to:

[www.datacard.com/califpropwarning](http://www.datacard.com/califpropwarning).



## Revision Log

Revision	Date	Description of Changes
Beta	April 2020	Beta release of this document
A	August 2020	First release of this document
B	July 2021	Update document for SLM configuration.
C	May 2024	Updated configuration codes for impresser die options



# Contents

<b>Chapter 1: Introduction</b> .....	<b>1</b>
<b>About this Manual</b> .....	<b>1</b>
<b>Intended Audience</b> .....	<b>1</b>
<b>Technical Support</b> .....	<b>1</b>
<b>Chapter 2: About the Card Lamination Module</b> .....	<b>3</b>
<b>The Laminator System</b> .....	<b>3</b>
<b>Site Requirements</b> .....	<b>4</b>
System Dimensions .....	4
Clearance Requirements .....	5
<b>About the Laminator</b> .....	<b>6</b>
Laminator Back and Left Side .....	6
Laminator Status Light .....	7
Laminator Front and Right Side .....	7
Inside the Laminator .....	8
<b>Load Laminator Overlay Material</b> .....	<b>11</b>
<b>Card Design</b> .....	<b>13</b>
<b>Verify Setup</b> .....	<b>13</b>
<b>Chapter 3: Laminator Maintenance</b> .....	<b>15</b>
<b>Clean the Laminator</b> .....	<b>15</b>
<b>Empty the Laminator Reject Tray</b> .....	<b>18</b>
<b>Chapter 4: Laminator Troubleshooting</b> .....	<b>19</b>
<b>Laminator Issues</b> .....	<b>19</b>
Patch Appearance Problems .....	19
Topcoat Appearance Problems .....	22
<b>Clear a Laminator Card Jam</b> .....	<b>24</b>
<b>Laminator Messages on the Printer LCD Panel</b> .....	<b>24</b>
177: Laminator not available .....	24
196: Laminator error critical .....	24
197: Laminator entry card problem .....	25
198: L1 area card problem .....	25
199: L2 area card problem .....	25
200: Laminator exit card problem .....	25
201: L1 supply problem .....	26
202: L1 supply out or missing .....	26
203: L1 supply type problem .....	26
204: L1 supply not supported .....	26
205: L1 supply not identified .....	26
206: L2 supply problem .....	27
207: L2 supply out or missing .....	27

208: L2 supply type problem . . . . .	27
209: L2 supply not supported . . . . .	27
210: L2 supply not identified . . . . .	27
211: L1 heater problem . . . . .	28
212: L2 heater problem . . . . .	28
213: L1 heater sensor problem . . . . .	28
214: L2 heater sensor problem . . . . .	28
215: L1 heater roller problem . . . . .	28
216: L2 heater roller problem . . . . .	29
217: Debow problem . . . . .	29
218: Impresser problem . . . . .	29
219: Impresser sensor problem . . . . .	29
220: Impresser heater problem . . . . .	30
221: Bar code scanner problem . . . . .	30
222: Firmware version mismatch . . . . .	30
223: Laminator system mismatch . . . . .	30
<b>Chapter 5: Laminator Supplies and Parts . . . . .</b>	<b>31</b>
<b>Laminator Supplies . . . . .</b>	<b>31</b>
Overlay Storage Guidelines . . . . .	34
<b>Cleaning Supplies . . . . .</b>	<b>34</b>
<b>Replacement Parts . . . . .</b>	<b>35</b>
Laminator Cartridges . . . . .	35
Impresser Die . . . . .	35
<b>Power Supplies . . . . .</b>	<b>35</b>
<b>Power Cords . . . . .</b>	<b>36</b>

# Chapter 1: Introduction



---

## About this Manual

This manual provides user information for the card lamination module. The manual includes:

- An overview of the laminator, and a description of the system label.
- How to load and replace supplies.
- How to perform routine maintenance and troubleshooting tasks.

Refer to the printer’s user documentation for information about setting up and using the printer.

## Intended Audience

The manual is intended for the printer operator who prints cards, loads and replaces supplies, maintains the printer, and performs troubleshooting.

## Technical Support

Use the following to contact Entrust Technical Phone Support.

Americas	+1 800.328.3996 or +1 952.988.2316
EMEA (Europe, Middle East, Africa)	+44 1489555627
Asia Pacific	+852 2821 0126



# Chapter 2: About the Card Lamination Module

# 2

This guide provides information about the optional card lamination module that you can add to your system at the time of purchase or later, as a field upgrade.

---

## The Laminator System

A laminator system consists of a Sigma card printer and a card lamination module. The system can print cards and apply an overlay material on the front and back of the card for increased durability and security. Using an overlay material with holographic or other transparent images also improves the security of the card.

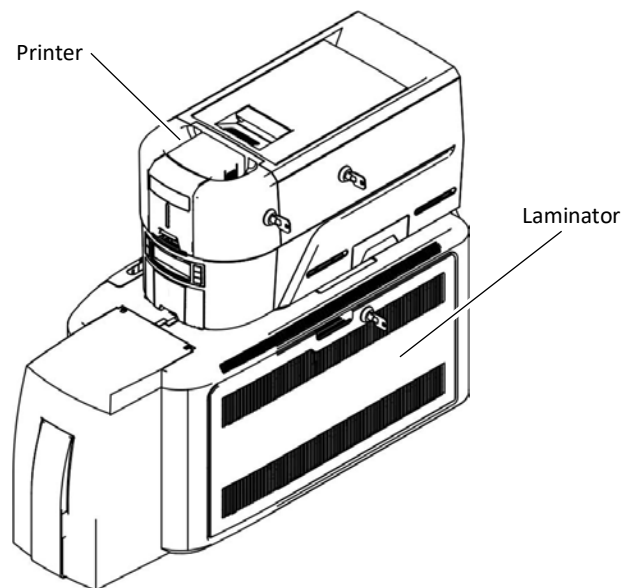

# Site Requirements

Provide space for the system and for clearance around the system.

## System Dimensions

The external system dimensions are shown in the following illustration.

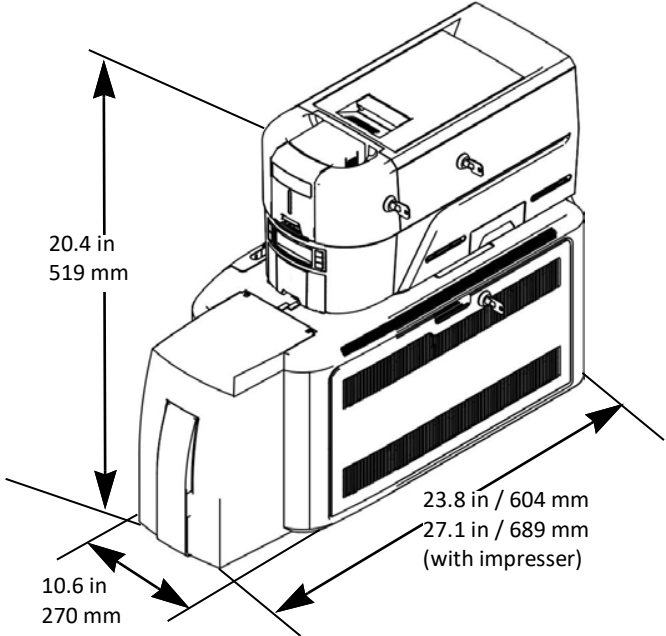

## Clearance Requirements

The following measurements show the system dimensions when the input hopper, printer cover, and laminator access doors are open.



Best practices recommend that you provide a minimum of 3 inches (76.2 mm) of additional clearance around the system to maintain access to the power cord and data cables, to load and remove cards and supplies, and to provide ventilation.

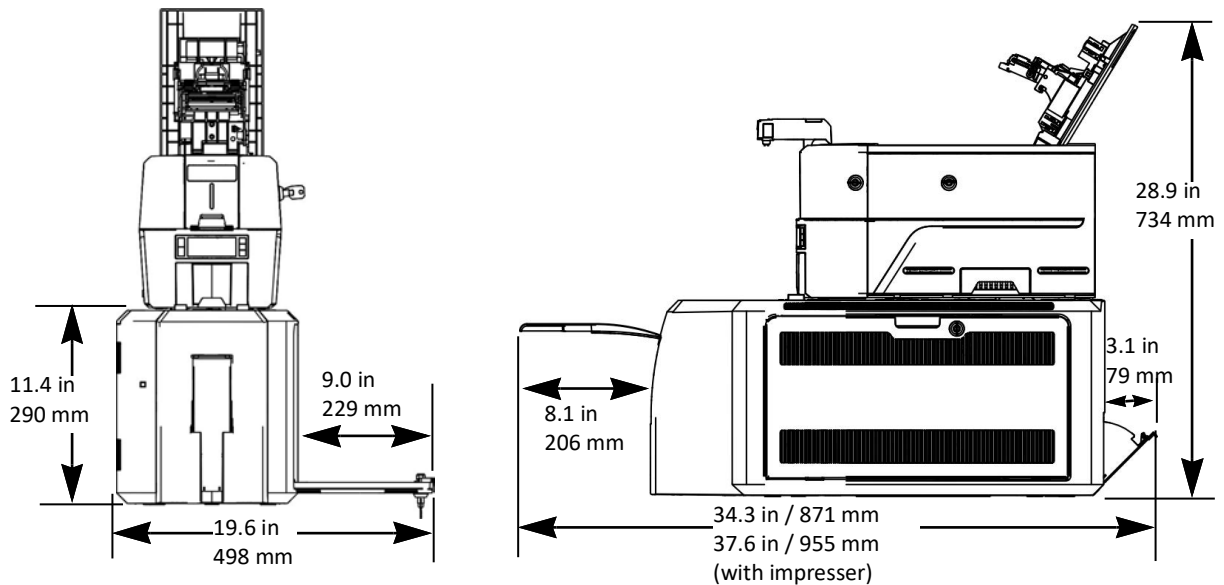

## Electrical Requirements

The power supply is rated as follows:

System Component	Electrical Requirements	
	Input	Output
Printer	100–200V/50–60 Hz/1.6 Amp	24V/3.0Amp/72W
Laminator with L1 only	100–240V/47–63 Hz/2.2 Amp	24V/3.75Amp/90W
Laminator with L1, L2, and impresser	100–240V/47–63 Hz/6.6 Amp	24V/6.6Amp/160W

# About the Laminator

Use the following information to become familiar with the laminator.



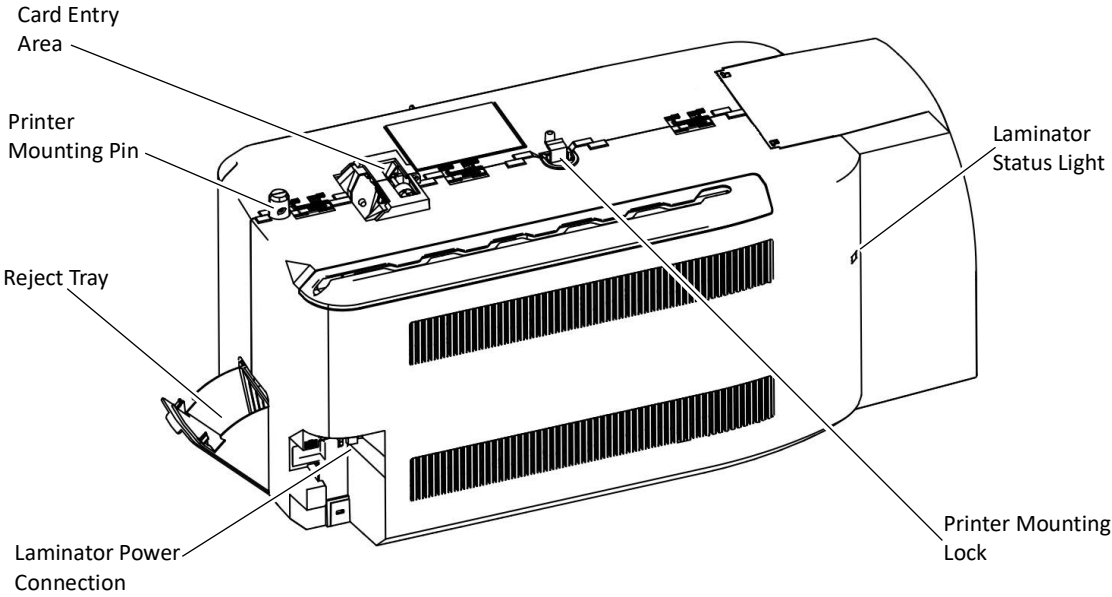

## Laminator Back and Left Side



- Printer Mounting Pin**      The pin aligns the printer with the laminator.
- Printer Mounting Lock**      The lock secures the printer to the laminator.
- Laminator Status Light**      The light shows the status of the laminator. Refer to [“Laminator Status Light”](#) on [page 7](#).
- Card Entry Area**      The card entry area receives the card from the printer and places it into position for laminating.
- Reject Tray**      Unfinished cards or cards not processed properly are placed in the reject tray.
- Laminator Power Connection**      The power connection provides a plug-in connector for the laminator power supply.

# Laminator Status Light

The status light shows the status of the laminator:

Ready	Solid green	
Busy	Blinking green	
Idle/Sleeping	Solid blue	
Heating	Blinking blue	
Error	Blinking red	

# Laminator Front and Right Side

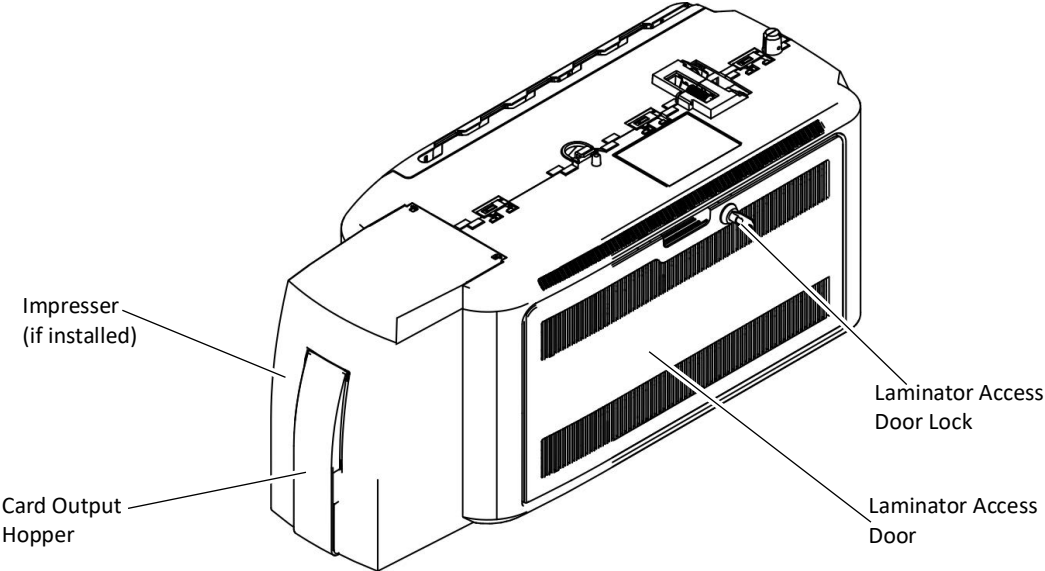

- Card Output Hopper**      The card output hopper holds up to 100 completed cards.
- Laminator Access Door**      The access door provides access to the laminator supplies.
- Laminator Access Door Lock**      The optional lock provides secure access to the laminator.  
**Note:** If the laminator has a lock, the printer also must have a lock.
- Impresser**      The optional impresser is located inside the laminator just before the card exit slot.

# Inside the Laminator

The card lamination module has one standard laminator, in the L1 position, with an optional second laminator in the L2 position. The laminators apply topcoat or patch overlay material to the card. Topcoat is a continuous film and patch is a die-cut polyester shape. Both laminators can apply either overlay type. Refer to [“Laminator Supplies”](#) on [page 31](#).

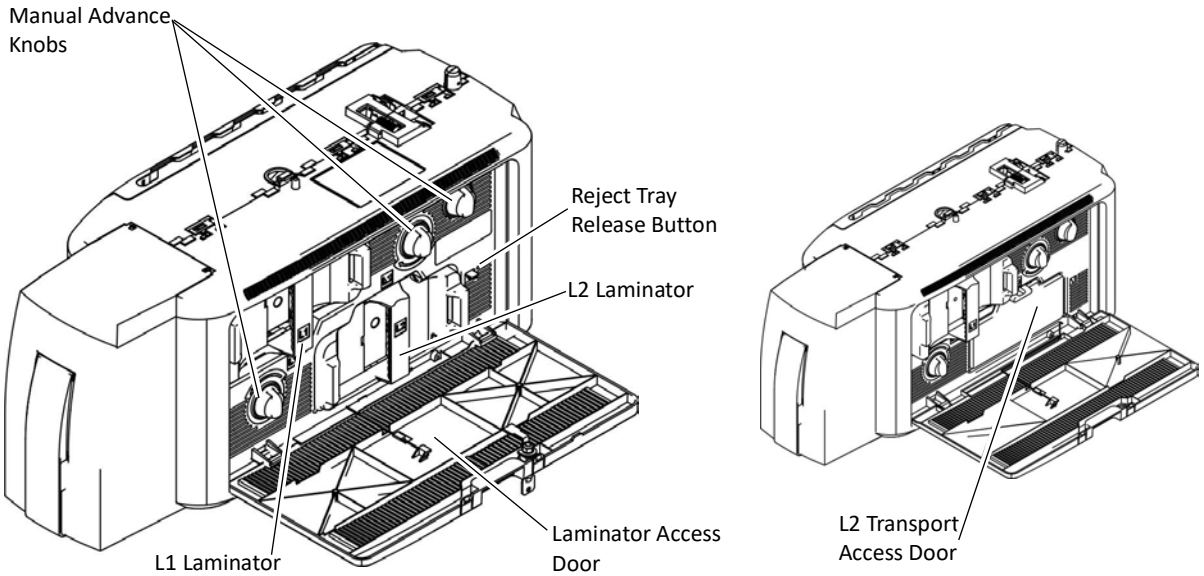

### Manual Advance Knobs

The manual advance knobs move the card through the laminator to remove it from the system. Use the knobs to clear a card jam. Refer to [“Clear a Laminator Card Jam”](#) on [page 24](#)

### L1 Laminator (green cartridge)

The L1 laminator cartridge holds the overlay material and applies it to the card.

### L2 Laminator (orange cartridge)

The L2 laminator cartridge holds overlay material and applies it to the card. The L2 laminator is optional.

### Reject Tray Release Button

The release button opens the reject tray to remove incomplete cards. Available only on systems with locks.

### Laminator Access Door

The access door provides access to the L1 and L2 laminators to load supplies or to clear a card jam.

### L2 Transport Access Door

The L2 transport access door replaces the L2 laminator cartridge if the optional second laminator is not installed. Open the door to access the laminator card transport.



If your system includes the optional second laminator (L2), make sure that the laminator cartridge is always installed even if the cartridge is not loaded with overlay material. If the cartridge is not in place, cards are not supported as they travel through the system and can fall into the bottom of the laminator.

# Laminator Configuration Label



The laminator configuration label is located inside the laminator on the laminator access door and beneath the L2 cartridge.

The configuration label shows the following information:

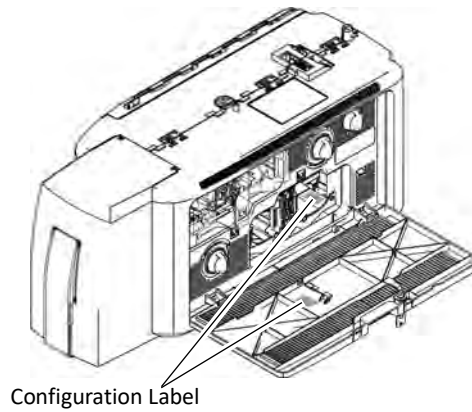
- Laminator model (SLM or CLM)
- Serial number
- Configuration
- Part number
- Date and country of assembly.



Additional labels may be attached to indicate options installed by the dealer or sales group after the laminator was manufactured.

<b>Model</b>	<b>CLM</b>	<b>SN: KM10001</b>	<b>Serial Number</b>
<b>Configuration</b>	<b>L2.K2.P1.V1</b>		
<b>Date of Manufacture</b>	<b>04/16/20</b>	<b>507968-002</b>	<b>Part Number</b>
	WO: 655555		

<b>Option</b>	<b>Configuration Code</b>
<b>Laminator</b>	L1=L1 Laminator, metal rollers L2=L1 and L2 Laminator, metal rollers L3=L1 Laminator, rubber rollers L4= L1 and L2 Laminator, rubber rollers L5=L1 Laminator, metal rollers; L2 Laminator, rubber rollers
<b>Locks</b>	K1=Mechanical Locks K2=Electronic/Mechanical Locks blank=no lock option
<b>Impresser Die</b>	P1=Standard Impresser Die P2xxx, P3xxx, P4xxx, P5xxx=Custom Impresser Die

<b>Option</b>	<b>Configuration Code</b>
<b>Impresser Track</b>	T1=Impresser Tack 1 T2=Impresser Tack 2 T3=Impresser Tack 3
<b>Enclosure</b>	V1=Sigma Card Printer (Dark Gray) V2=Sigma Card Printer (White) blank=CD Card Printer

# Load Laminator Overlay Material

Load the overlay material in one laminator cartridge at a time.

 The L1 (green) and L2 (orange) cartridges fit only in their assigned locations inside the laminator. They are not interchangeable.

1. Unlock and open the laminator access door.
2. Remove the L1 (green) laminator cartridge from the printer. Place the cartridge on a smooth level surface for loading.

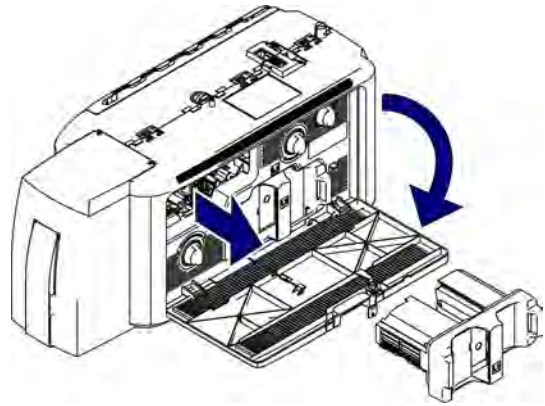

3. Push the release latch (a) and open the gate on the laminator cartridge (b).

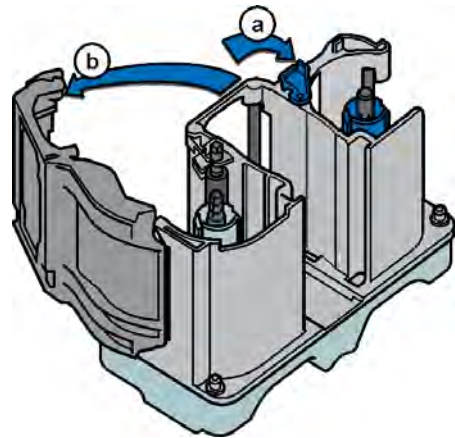

4. Remove both used spools from the cartridge.

5. Load the new roll of laminator overlay material.
  - a. Put the blue supply spool on the blue supply spindle of the cartridge (c). The overlay supply roll can go on only one way and only fits on the correct spindle.
  - b. Put the empty silver take-up spool on the silver take-up spindle (d).
  - c. Turn the take-up spool clockwise to remove slack from the material (e). The overlay material loads in an S-shape.

Make sure that the overlay material is between the guides on both the take-up and supply sides of the cartridge.

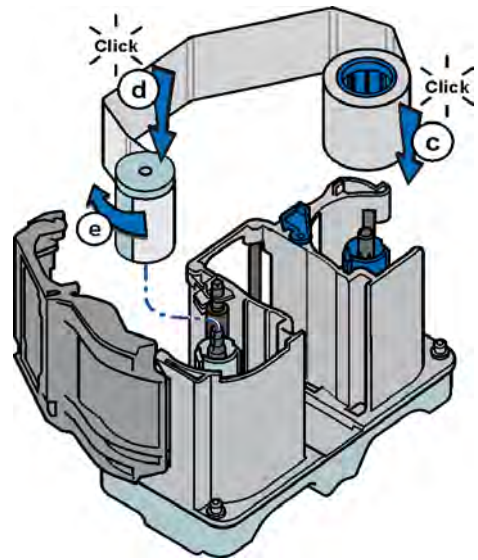

6. Close the laminator cartridge gate (f). Push it in until the latch clicks in place (g). Make sure that the overlay material is not pinched by the cartridge gate.
7. Replace the loaded laminator cartridge in the printer.
8. Remove the L2 (orange) cartridge, if installed, from the laminator.
9. Repeat steps 3 through 7 to load the overlay onto the L2 cartridge.
10. Close and lock the laminator access door.

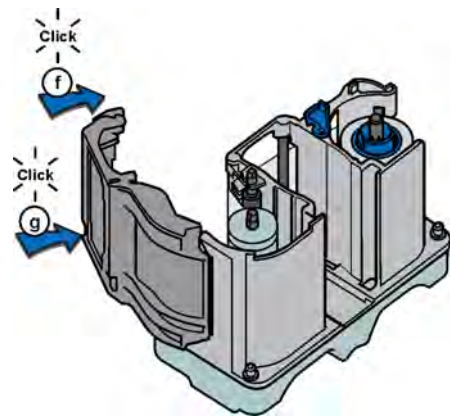

# Card Design

Set up your card design using your card production software or another application, such as Microsoft Word. You can specify your lamination preferences using the Card Printer Driver or your card production software.

The Card Printer Driver allows you to specify both printer and lamination preferences. Refer to the *XPS Card Printer Driver User's Guide* for complete information about setting up printing preferences and lamination options.

- If the printer has one laminator, you can apply the overlay material to one or both sides of the card.
- If the printer has two laminators using different overlay materials, the quickest way to process a card is to apply the overlay in L1 to the front of the card and the overlay in L2 to the back of the card.

You can fine-tune the settings that control the application of the overlay using the Printer Dashboard. Refer to the Printer Dashboard Help for more information.

# Verify Setup

After you set up the laminating system, print several test cards to determine how well the laminator applies material to the card. You can print test cards from the Card Printer Driver (refer to the *XPS Card Printer Driver User's Guide*), from the printer LCD panel (refer to the printer's *User's Guide*), or from the Printer Dashboard (refer to the Printer Dashboard Help). You may need to print multiple test cards to make sure that the overlay is positioned correctly. The card stock, the card design, and the printer's environment all can affect the appearance of cards.

When evaluating a card, make sure that:

- The overlays are being applied properly:
  - Each overlay is applied completely to the card.
  - The material adheres well to the edges of the card.
  - The overlay does not come off when the card is bent or twisted.
- The card is debowed correctly.
- The impression is positioned correctly and has the proper depth.

If you need to make adjustments to the laminator or overlay settings, refer to the Printer Dashboard Help.



# Chapter 3: Laminator Maintenance

# 3

This chapter provides information to help you maintain the laminator for optimal performance.

---

## Clean the Laminator

Clean the laminator when at least one laminator cartridge is loaded with holographic overlay material and any of the following are true:

- Particles appear on the laminated cards.
- Particles are visible inside the laminator.

For examples of problems that require laminator cleaning, refer to [“Laminator Issues”](#) on [page 19](#).



This procedure uses a double-sided, adhesive cleaning card that removes holographic overlay particles from the laminator. When you clean the printer using an isopropanol cleaning card, the card also moves into the laminator and cleans the laminator rollers, the card entry area, and the impresser exit rollers. This is sufficient if you are not using holographic overlay. Refer to the printer’s *User’s Guide* for information about cleaning the printer.

1. Unlock the laminator access door and remove the L1 and L2 laminator cartridges.

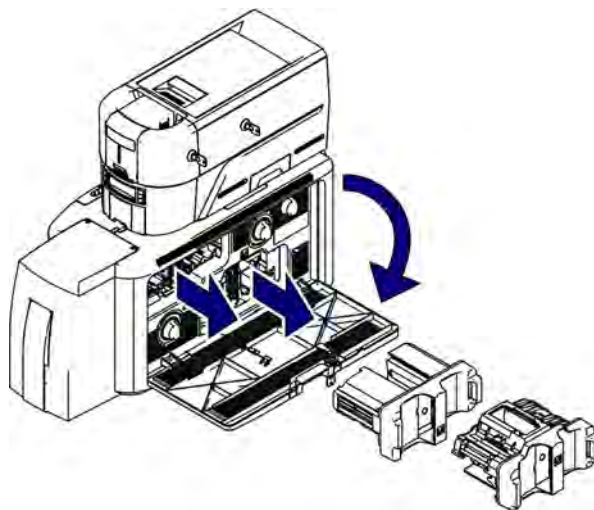

2. Remove any printed cards from the output hopper.
3. Peel off the center strips from both sides of the adhesive cleaning card. Leave the side strips in place.

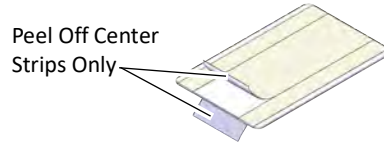

4. Insert the cleaning card under the rollers of the card exit slot of the laminator. When it is in the correct location and pushed in far enough, the card stays in place.

If the cleaning card appears bowed, insert it as shown.

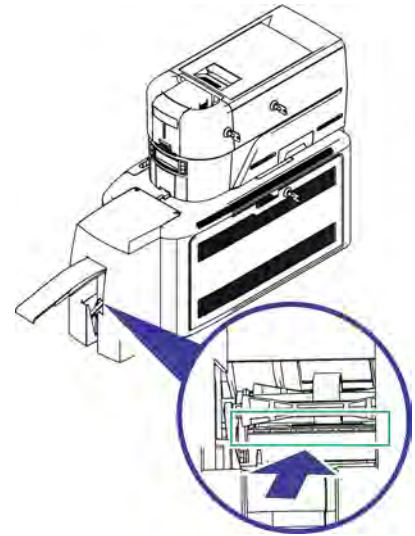
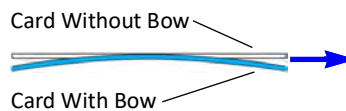

5. Use the LCD menu system to start the cleaning cycle.
  - a. Begin when the printer displays **Ready**. Press the USER button.
  - b. **Suspended** displays on line 1 of the LCD panel. Press ENTER to enter the menu system.
  - c. **Maintenance** displays on line 3 of the LCD panel. Press ENTER to enter the Maintenance menu.
  - d. **Cleaning Card** displays on line 3 of the LCD panel. Press ENTER to enter the Cleaning Card menu.

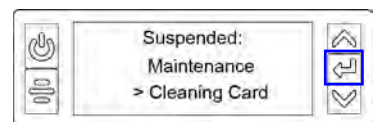
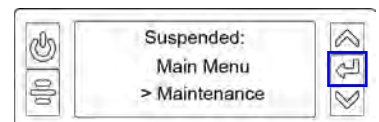
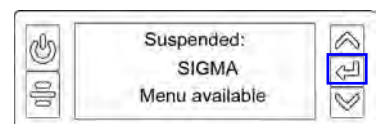
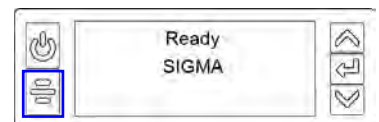

- e. **Printer** displays on Line 3 of the LCD panel. Press the down arrow.

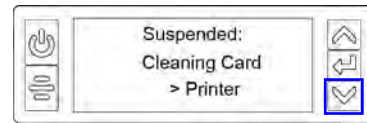

- f. **Laminator** displays on line 3. Press ENTER.

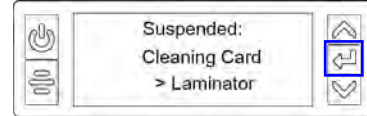

- g. **Start** displays on line 3. Press ENTER to start the cleaning process.

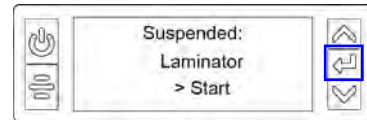

- h. **Insert cleaning card** displays on the LCD panel. Press the USER button to start the cleaning cycle.



The laminator pulls the cleaning card from the card exit slot into the laminator and moves it back and forth through the L1 and L2 cartridge areas, the card entry area, and the exit rollers several times. The used cleaning card is ejected into the laminator reject tray.

6. Inspect the laminator cartridges for particles. If particles are present:
  - a. Retrieve the cleaning card and use it to remove the particles of overlay material from the cartridges.
  - b. If particles still remain on the cartridge and inside of the laminator, use a vacuum cleaner with a small plastic hose attachment to carefully remove the particles. Also clean any remaining particles from the output hopper.

#### HINTS & TIPS

- If the cleaning card is not pulled into the laminator, the card is not in the correct position. The cleaning card must be located under the rollers of the card exit slot inside the output hopper.
- At the end of the laminator cleaning cycle, the card can stick to the rollers in the output hopper. Pull on the card to remove it.
- Discard the cleaning card after one use.
- Avoid contact with the heated roller, which contains sensitive electronic components.
- If cleaning the laminator does not solve the problem, contact your service provider for assistance.

# Empty the Laminator Reject Tray

Unfinished cards, or cards that were not processed properly, are placed in the laminator reject tray.



The printer reject tray is not used when the laminator is present. Rejected cards are always placed in the laminator reject tray

1. Unlock and open the laminator access door.
2. Press the reject tray release button to open the laminator reject tray. (Refer to [“Inside the Laminator”](#) on [page 8.](#))
3. Remove the rejected cards from the reject tray.
4. Close the reject tray.
5. Close and lock the laminator access door.

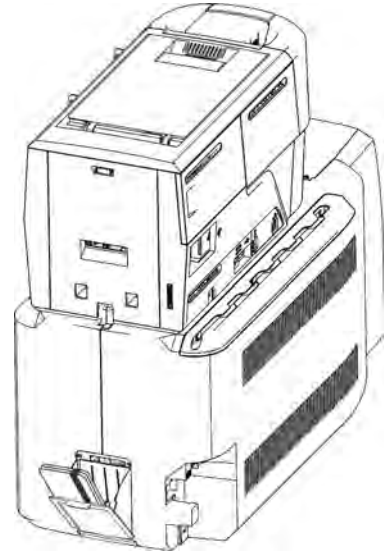

# Chapter 4: Laminator Troubleshooting

# 4

This chapter provides information to help you identify and fix basic issues that can occur when using the laminator.

---

## Laminator Issues

This section describes issues that might occur when you use a laminator to apply a patch or topcoat overlay to the card.

### Patch Appearance Problems

Problem	Probable Cause	Solution
Smart cards don't work after the overlay is applied.	The Debow card option is selected.	Make sure that the Debow card option in the Card Printer Driver is not selected. Refer to the <i>XPS Card Printer Driver User's Guide</i> for information about specifying the debow option.
Cards are bowed too much.	The Debow card option is not selected.	Select the Debow card option in the Card Printer Driver. Refer to the <i>XPS Card Printer Driver User's Guide</i> .
	Debow time is not set correctly.	Change the card debow time. Refer to the Printer Dashboard Help for more information.
	The temperature is too high for the card stock used.	Lower the laminator temperature for the overlay material. Refer to the Printer Dashboard Help for more information.
	The card stock doesn't work with the overlay.	Switch to a different card stock.

<b>Problem</b>	<b>Probable Cause</b>	<b>Solution</b>
The patch comes off when the card is flexed.	The temperature is too low for the overlay material.	Increase the laminator temperature for the overlay material. Refer to the Printer Dashboard Help for more information.
	A patch is stuck to the heated roller.	Clean the laminator. Refer to <a href="#">“Clean the Laminator”</a> on page 15. If the problem continues to occur, contact your service provider.
There are scratches or particles under the patch.	The inside of the printer is dirty.	Clean the printer. Refer to the printer’s <i>User’s Guide</i> .
	The supplies have debris on them.	Store and handle supplies carefully. Keep supplies in the original packaging until you are ready to use them.
There are repeating marks on the patch.	The heated roller is dirty.	Clean the laminator. Refer to <a href="#">“Clean the Laminator”</a> on page 15. If the problem continues to occur, contact your service provider.
The patch doesn’t adhere to the trailing edge of the card.	The overlay is wound incorrectly on the take-up spool.	Process another card to allow the overlay material to reset itself. If it doesn’t, remove the cartridge and turn the take-up spool clockwise several turns.
The patch is not centered between the long edges of the card.	The overlay is not loaded correctly in the cartridge.	Load the overlay material correctly. Refer to <a href="#">“Load Laminator Overlay Material”</a> on page 11.
	The laminator cartridge is not fully seated in the laminator.	Make sure that the cartridge is seated in the laminator properly.
	The overlay material is wound unevenly on the supply roll.	Process several cards to allow the overlay material to center itself. Align the edges of the overlay on the take-up spool.
	The laminator cartridge is damaged.	Replace the laminator cartridge.

<b>Problem</b>	<b>Probable Cause</b>	<b>Solution</b>
The patch has wavy lines along the length of the card.	The temperature for applying the overlay is set too high.	Decrease the laminator temperature setting. Refer to the Printer Dashboard Help for more information.
	The heated roller is damaged.	Power off the system. Contact your service provider for assistance.
	The card has features, such as a smart card chip, that interfere with application of the overlay.	Use the correct patch material for your card type. Refer to <a href="#">“Laminator Supplies”</a> on <a href="#">page 31</a> for a description of overlay types.
The patch shows opaque areas at the leading edge of the card.	The temperature for applying the overlay is too high.	Decrease the laminator temperature setting. Refer to the Printer Dashboard Help for more information. If the problem continues to occur, contact your service provider for assistance.
The patch extends beyond one of the short edges of the card.	There is slack in the overlay material.	Process another card to allow the overlay material to reset itself.
	The overlay material is wound incorrectly on the take-up spool.	Remove the laminator cartridge and turn the take-up spool clockwise several turns.
	The card or overlay registration settings are not correct.	Contact your service provider for assistance.
The patch is missing from the finished card.	The supply spool is not positioned correctly in the cartridge.	Make sure that the overlay is loaded correctly. Refer to <a href="#">“Load Laminator Overlay Material”</a> on <a href="#">page 11</a> .
	The overlay was moved on the spool and the patch was used previously.	Advance the overlay past the used area. If the problem continues to occur, contact your service provider.
	The Card Printer Driver Laminated card setting was set to Do not apply.	Change the Laminated card setting to apply the overlay. Refer to the <i>XPS Card Printer Driver User’s Guide</i> for information about specifying lamination settings.

## Topcoat Appearance Problems

Problem	Probable Cause	Solution
There are scratches in the topcoat.	The inside of the printer is dirty.	Clean the printer. Refer to the printer's <i>User's Guide</i> for information about cleaning the printer.
	The supplies have debris on them.	Store and handle supplies carefully. Keep supplies in the original packaging until you are ready to use them.
There are repeating marks in the topcoat.	The heated roller is dirty.	Clean the laminator. Refer to " <a href="#">Clean the Laminator</a> " on <a href="#">page 15</a> . If the problem continues to occur, contact your service provider.
The holographic topcoat shows irregular darker areas.	The temperature for applying the holographic topcoat is too high.	Decrease the laminator temperature for the overlay material. Refer to the Printer Dashboard Help for more information.
There are particles of holographic topcoat beyond the trailing edge of the card.	The temperature for applying the holographic topcoat is too high.	<ul style="list-style-type: none"> <li>• Topcoat particles, or flash, can become attached to the card. Try to brush off the particles.</li> <li>• Clean the laminator. Refer to "<a href="#">Clean the Laminator</a>" on <a href="#">page 15</a>.</li> <li>• Decrease the laminator temperature for the overlay material. Refer to the Printer Dashboard Help for more information.</li> </ul> <p><b>Note:</b> Reducing the temperature can reduce the number of particles, but does not eliminate them.</p>
The topcoat shows wavy lines along the length of the card.	The temperature for applying the topcoat is too high.	Decrease the laminator temperature for the overlay material. Refer to the Printer Dashboard Help for more information.
The topcoat shows opaque areas along a short edge of the card.	The temperature for applying the topcoat is too high.	Decrease the laminator temperature for the overlay material. Refer to the Printer Dashboard Help for more information. If the problem continues to occur, contact your service provider for assistance.

<b>Problem</b>	<b>Probable Cause</b>	<b>Solution</b>
The topcoat is spotty, especially on the leading edge of the card.	The overlay material is wound in the wrong direction on the take-up spool.	Process another card to allow the overlay material to reset itself. If it doesn't, remove the cartridge and turn the take-up spool clockwise several turns.
The hologram of the topcoat doesn't appear on the card.	The Card Printer Driver Lamine card setting is set to Do not apply.	Change the Lamine card setting to apply the overlay. Refer to the <i>XPS Card Printer Driver User's Guide</i> for information about specifying lamination settings.
	Clear topcoat is installed in the cartridge.	Remove the cartridge and change the overlay to the correct type.
	The overlay material is wound in the wrong direction on the take-up spool.	Process another card to allow the overlay material to reset itself. If it doesn't, remove the cartridge and turn the take-up spool clockwise several turns.
	The overlay is not loaded correctly in the cartridge.	Remove the cartridge and reload the overlay. Refer to " <a href="#">Load Laminator Overlay Material</a> " on <a href="#">page 11</a> .
A long edge of the topcoat doesn't stick to the card.	The temperature of the heated roller is too low	Increase the laminator temperature for the overlay. Refer to the Printer Dashboard Help for more information.
	Print ribbon that includes a topcoat (T) panel is loaded in the printer.	Change the print ribbon to one that doesn't include a T panel.
	The cards do not meet specifications.	Use a different supply of cards.
	The overlay material was wound in the wrong direction on the take-up spool.	Process another card to allow the overlay material to reset itself. If it doesn't, remove the cartridge and turn the take-up spool clockwise several turns.
	There is debris on the heated roller.	Process several cards to see if the problem corrects itself. If it doesn't, clean the laminator. Refer to " <a href="#">Clean the Laminator</a> " on <a href="#">page 15</a> .

# Clear a Laminator Card Jam

1. Open the laminator access door.
2. Remove the L1 and L2 (if installed) laminator cartridges.
3. Turn the manual advance knobs inside of the laminator until the card is accessible.
4. Remove the card.
5. Replace the laminator cartridges.
6. Close the laminator access door.

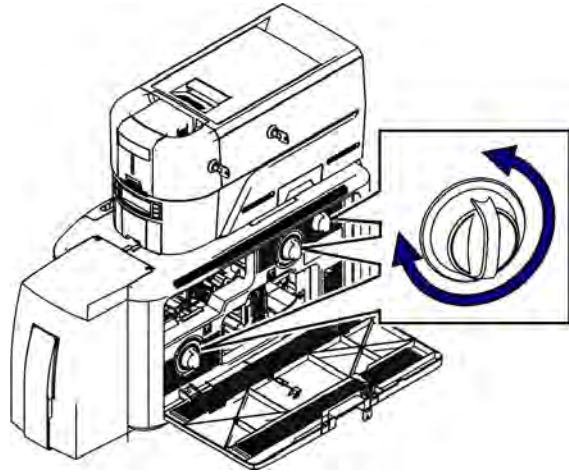

# Laminator Messages on the Printer LCD Panel

When an error occurs processing a card, an error message displays on the printer LCD panel. Refer to the printer's *User's Guide* for a list of printer messages.

The following messages display on the printer LCD panel when you are using a laminating system. They also display in a message on the PC that issued the card print job when you use the Card Printer Driver, and in the Printer Dashboard.

## 177: Laminator not available

The printer and laminator cannot communicate. The card will be canceled.

1. Make sure the data cable from the laminator to the printer is securely plugged in.
2. Press the printer POWER button to power off the system.
3. Press the POWER button again to power on the system.

In the Card Printer Driver message, click **Retry**, or click **Cancel** to cancel the card.

## 196: Laminator error critical

The laminator has encountered a critical error. The card will be canceled.

1. Press the printer POWER button to power off the system.
2. Request service. The system must remain powered off.

Click **OK** to clear the message from the Card Printer Driver message on the PC.

## 197: Laminator entry card problem

The card is not where it should be in the laminator.

1. Open the laminator.
2. Turn the knob to remove the card.
3. Close the laminator.

In the Card Printer Driver message, click **Retry**, or click **Cancel** to cancel the card.

## 198: L1 area card problem

The card is not where it should be in the laminator.

1. Open the laminator and remove the L1 supply cartridge.
2. Turn the knob to remove the card.
3. Replace the supply cartridge and close the laminator.

In the Card Printer Driver message, click **Retry**, or click **Cancel** to cancel the card.

## 199: L2 area card problem

The card is not where it should be in the laminator.

1. Open the laminator and remove the L2 supply cartridge.
2. Turn the knob to remove the card.
3. Replace the supply cartridge and close the laminator.

In the Card Printer Driver message, click **Retry**, or click **Cancel** to cancel the card.

## 200: Laminator exit card problem

The card is not where it should be in the laminator.

1. Open the laminator.
2. Turn the knob to remove the card.
3. Close the laminator.

In the Card Printer Driver message, click **Retry**, or click **Cancel** to cancel the card.

## 201: L1 supply problem

The L1 supply is not moving properly. To try another card:

1. Open the laminator and remove the L1 cartridge.
2. Reposition, repair, or replace the supply and advance the repaired area one full turn.
3. Replace the cartridge and close the laminator.

In the Card Printer Driver message, click **Retry**, or click **Cancel** to cancel the card.

## 202: L1 supply out or missing

The laminator does not have usable supplies.

1. Open the laminator.
2. Replace the supply.
3. Close the laminator.

In the Card Printer Driver message, click **OK**, or click **Cancel** to cancel the card.

## 203: L1 supply type problem

The laminator cannot use the supply installed.

Use supplies designed for this laminator.

In the Card Printer Driver message, click **Retry**, or click **Cancel** to cancel the card.

## 204: L1 supply not supported

The laminator cannot use the supply installed.

Use supplies designed for this laminator.

In the Card Printer Driver message, click **Retry**, or click **Cancel** to cancel the card.

## 205: L1 supply not identified

The laminator cannot use the supply installed.

Use supplies designed for this laminator.

In the Card Printer Driver message, click **Retry**, or click **Cancel** to cancel the card.

## 206: L2 supply problem

The L2 supply is not moving properly. To try another card:

1. Open the laminator and remove the L2 cartridge.
2. Reposition, repair, or replace the supply and advance the repaired area one full turn.
3. Replace the cartridge and close the laminator.

In the Card Printer Driver message, click **Retry**, or click **Cancel** to cancel the card.

## 207: L2 supply out or missing

The laminator does not have usable supplies.

1. Open the laminator.
2. Replace the supply.
3. Close the laminator.

In the Card Printer Driver message, click **OK**, or click **Cancel** to cancel the card.

## 208: L2 supply type problem

The laminator cannot use the supply installed.

Use supplies designed for this laminator.

In the Card Printer Driver message, click **Retry**, or click **Cancel** to cancel the card.

## 209: L2 supply not supported

The laminator cannot use the supply installed.

Use supplies designed for this laminator.

In the Card Printer Driver message, click **Retry**, or click **Cancel** to cancel the card.

## 210: L2 supply not identified

The laminator cannot use the supply installed.

Use supplies designed for this laminator.

In the Card Printer Driver message, click **Retry**, or click **Cancel** to cancel the card.

## 211: L1 heater problem

The laminator has encountered a critical error. The card will be canceled.

1. Press the printer POWER button to power off the system.
2. Request service. The system must remain powered off.

Click **OK** to clear the message from the Card Printer Driver message on the PC.

## 212: L2 heater problem

The laminator has encountered a critical error. The card will be canceled.

1. Press the printer POWER button to power off the system.
2. Request service. The system must remain powered off.

Click **OK** to clear the message from the Card Printer Driver message on the PC.

## 213: L1 heater sensor problem

The laminator has encountered a critical error. The card will be canceled.

1. Press the printer POWER button to power off the system.
2. Request service. The system must remain powered off.

Click **OK** to clear the message from the Card Printer Driver message on the PC.

## 214: L2 heater sensor problem

The laminator has encountered a critical error. The card will be canceled.

1. Press the printer POWER button to power off the system.
2. Request service. The system must remain powered off.

Click **OK** to clear the message from the Card Printer Driver message on the PC.

## 215: L1 heater roller problem

The laminator has encountered a critical error. The card will be canceled.

1. Press the printer POWER button to power off the system.
2. Request service. The system must remain powered off.

Click **OK** to clear the message from the Card Printer Driver message on the PC.

## 216: L2 heater roller problem

The laminator has encountered a critical error. The card will be canceled.

1. Press the printer POWER button to power off the system.
2. Request service. The system must remain powered off.

Click **OK** to clear the message from the Card Printer Driver message on the PC.

## 217: Debow problem

The laminator has encountered an error in the debow area.

1. Remove the card.
2. Press the printer POWER button to power off the system.
3. Press the printer POWER button again to power on the system.
4. If the problem occurs again, request service.

In the Card Printer Driver message, click **Retry**, or click **Cancel** to cancel the card.

## 218: Impresser problem

The laminator has encountered a critical error. The card will be canceled.

1. Press the printer POWER button to power off the system.
2. Request service. The system must remain powered off.

Click **OK** to clear the message from the Card Printer Driver message on the PC.

## 219: Impresser sensor problem

The laminator has encountered a critical error. The card will be canceled.

1. Press the printer POWER button to power off the system.
2. Request service. The system must remain powered off.

Click **OK** to clear the message from the Card Printer Driver message on the PC.

## 220: Impresser heater problem

The laminator has encountered a critical error. The card will be canceled.

1. Press the printer POWER button to power off the system.
2. Request service. The system must remain powered off.

Click **OK** to clear the message from the Card Printer Driver message on the PC.

## 221: Bar code scanner problem

The bar code scanner cannot read the bar code on the overlay. This can indicate a scanner problem, an unreadable bar code, or an incorrect L1 cartridge.

Try the card again.

If the problem occurs again, request service.

Click **OK** to clear the message from the Card Printer Driver message on the PC.

## 222: Firmware version mismatch

The printer and laminator firmware versions are not compatible. The system cannot laminate cards until the firmware has been updated.

Update both the printer and laminator to the latest firmware versions.

## 223: Laminator system mismatch

The printer and laminator are not compatible.

The laminator is not supported by your printer model. Contact your service provider for the correct laminator model.



# Chapter 5: Laminate Supplies and Parts

# 5

This chapter describes the supplies and replacement parts available for the card lamination module.

---

## Laminator Supplies

The laminating system supports full-color print ribbons that do not have a topcoat (T) panel, including YMCK and YMCK-K ribbon. The topcoat or patch overlay applied by the laminators provide protection against wear and color fading, so the print ribbon topcoat panel is not needed. However, DuraShield clear and holographic overlays require that the ribbon topcoat be applied to the card first.

The system also supports full-color print ribbon with a front-side ultraviolet (UV) fluorescent panel, YMCKF-KT. The UV (F) panel is designed to create an optically variable image on the card. Refer to the *XPS Card Printer Driver User's Guide* or the documentation for your card production application for information about designing a card to use a UV ribbon.

Refer to the printer's *Installation and Administrator's Guide* for a list of supported ribbon types.

## Laminator Overlay Materials

The L1 and L2 laminators can apply either topcoat or patch material. Topcoat is a continuous film and patch is a die-cut polyester shape.

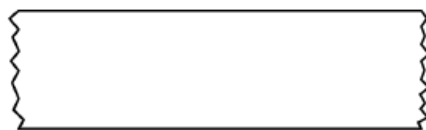

Topcoat



Patch

Patch overlays have a registration mark that is used by the printer to align the patch with the beginning of the card. The registration mark is a rectangular hole between the patches.

Patches can cover the entire card, can have an opening for a smart card chip, or can cover the card under the magnetic stripe. If both L1 and L2 laminators are installed, each laminator can apply different overlay material. For example, you might apply a patch that covers the complete card on the front, and a patch sized for a magnetic stripe on the back.

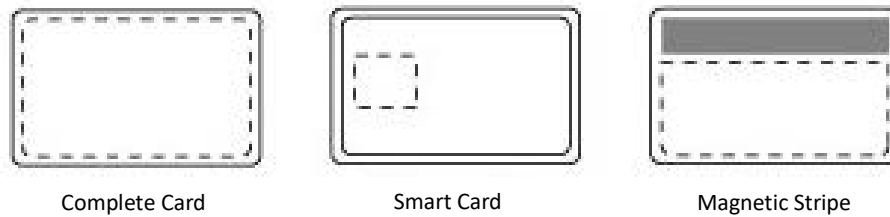

Both patch and topcoat overlays can be clear or can have a transparent holographic image on them. The holographic materials are called holographic topcoat or holographic patch and can be ordered with a custom image.

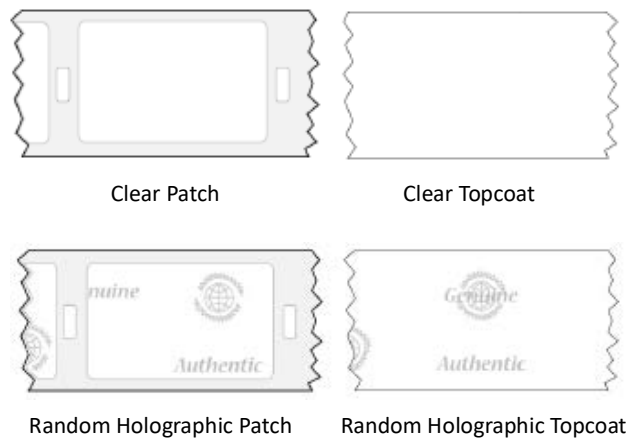

In addition, both holographic topcoat and holographic patch can be designed with a registered image that is located in the same position on each card. Registered holographic topcoat has a registration mark so that the image can be aligned with the card.

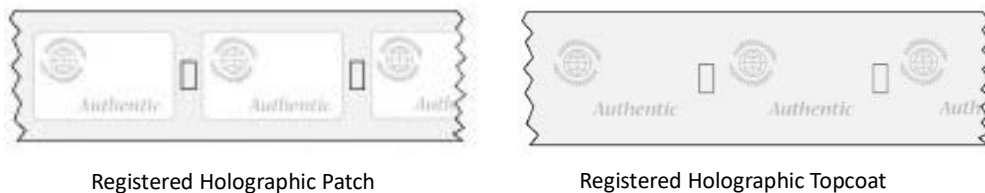

If you use a custom holographic overlay, make sure that you know the location of important card features, such as photos and logos. Do not place holographic images where they interfere with the appearance of photos or machine-readable features.

The following laminator supplies are available. Most are available for a full card, smart card, or magnetic stripe card.

**Patch Overlays:**

- Clear DuraGard®, 0.5 mil, up to 350 images/roll
- Clear DuraGard, 1.0 mil, up to 300 images/roll
- Holographic DuraGard 0.6 mil, Random, up to 350 images/roll
- Holographic DuraGard, Registered, 0.6 mil, up to 350 images/roll
- Holographic DuraGard, 1.0 mil, Random, up to 300 images/roll
- Holographic DuraGard Registered, 1.0 mil, up to 300 images/roll
- Holographic DuraGard, Registered, Serialized, 1.0 mil, up to 300 images/roll



**Caution:** DuraGard patch overlay cannot be applied over a “T” panel topcoat applied from a ribbon. Make sure that the DuraGard patch is applied to the card side without a “T” panel topcoat.

**Topcoat Overlays:**

- Clear, number of images depends on lamination settings
- Holographic, Random, number of images depends on lamination settings
- Registered Holographic, up to 600 images/roll
- Clear DuraShield™, number of images depends on lamination settings



DuraShield clear overlays must be used with a ribbon that includes an inline topcoat (T) panel, for example, KT, YMCKT, YMCKT-K, YMCKT-KT, ymckT, or YMCKF-KT. It must be applied over the topcoat.

## Overlay Storage Guidelines

- Store overlay material in the original package until you load it in the laminator. Keep the original packaging closed until you are ready to use the overlay.
- The overlay maintains its quality for about one year. For optimum card quality, purchase and store quantities of material that can be used within one year.
- Overlay material might require secure storage and tracking. Follow your organization's policy for storing and tracking the supplies used to make cards.
- Store the overlay in a location away from direct sunlight, with a temperature between 50° and 80°F (10° and 27°C). A range of 30% to 70% humidity is recommended.
- Install supply rolls at room temperature. If supplies are stored in an environment that is cooler than the printer environment, allow supplies to reach room temperature before you use them.
- If the printer will not be used for an extended period, remove supplies from the printer and store them with new supplies.

## Cleaning Supplies

When you clean the system using an isopropanol cleaning card, the card moves into the laminator after cleaning the printer and cleans the laminator rollers, the card entry area, and the impresser exit rollers. This is sufficient if you are not using holographic overlay. If you do use a holographic overlay, use a double-sided, adhesive cleaning card to remove holographic overlay particles from the laminator. Refer to [“Clean the Laminator”](#) on [page 15](#).

524405-001	Adhesive cleaning card	Pack of 10 adhesive cleaning cards
------------	------------------------	------------------------------------

# Replacement Parts

## Laminator Cartridges

The green L1 and orange L2 cartridges hold the laminator overlay material. They are used in the optional card lamination module only.

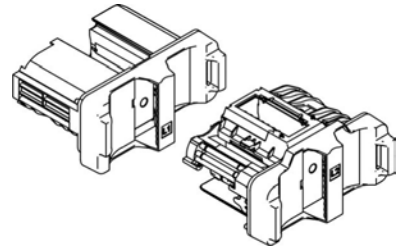

## Impresser Die

Contact your authorized service provider to special-order a new die for your impresser. The die must be installed by an authorized service provider.

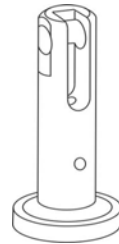

## Power Supplies

The laminator power supplies are rated as follows:

- Laminator with L1 only:
  - Input: 100–240V, 47–63Hz, 2.2A
  - Output: 24V, 3.75A, 90W
- Laminator with L1 and L2:
  - Input: 100–240V, 47–63Hz, 2.2A
  - Output: 24V, 6.6A, 160W

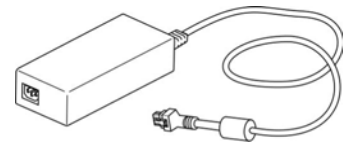

Laminator power supplies are self-adjusting within the rated input voltage

# Power Cords

The laminator power cord connects the laminator power supply to the facility power. Be sure to use power cords that ground to the facility power source.

The following country-specific power cords are available:

- USA Power cord
- Australia power cord
- Brazil power cord
- China power cord
- Denmark power cord
- European power cord
- India power cord
- Israel power cord
- Italy power cord
- Japan power cord
- South Africa power cord
- Swiss power cord
- United Kingdom power cord

